

1107 MAIN

HAMILTON

PLATINUM PROMOTIONS

EXTENDED DEPOSIT STRUCTURE

\$10,000 on Signing

Balance to 5% in 15 days

5% in 180 days

5% on February 1, 2025

5% three months prior to Occupancy

Payable to Levy Zavet PC in Trust

CAPPED DEVELOPMENT CHARGES

1 Bedroom & Den and Smaller at \$12,000

2 Bedroom and Larger at \$15,000

SMART HOME TECH PACKAGE

FURNISHED SUITE PACKAGES,

2 YEAR LEASE GUARANTEE

AND RENTAL MANAGEMENT

or

CREDIT ON CLOSING

\$10,000 for 1 Bedroom & Den Suites and Smaller

\$15,000 for 2 Bedroom Suites and Larger

\$500 ASSIGNMENT FEE + \$1,250 LEGAL FEE

(Reduced from \$5,000 + \$1,250 Legal Fee)

*Availability, features, promotions, and prices are subject to change without notice.
Some conditions apply. Please consult an RDS Sales Representative for details.

1107 MAIN

HAMILTON

SUITE INFORMATION: **SALES OFFICE USE ONLY**

SUITE # _____

UNIT PRICE \$ _____

PARKING _____

PARKING \$ _____

LOCKER _____

LOCKER \$ _____

TOTAL PRICE \$ _____

Worksheet Date	_____
Appointment Date	_____

1 st Choice Model	_____
2 nd Choice Model	_____
3 rd Choice Model	_____

PURCHASER ONE INFORMATION: **PURCHASER TWO INFORMATION:**

All fields are mandatory.

All fields are mandatory.

First Name:	First Name:
Last Name:	Last Name:
Address:	Address:
City:	City:
Province:	Province:
Country:	Country:
Postal Code:	Postal Code:
Phone #:	Phone #:
Email:	Email:
Date of Birth (MM/DD/YY):	Date of Birth (MM/DD/YY):
Government-Issued Photo ID #:	Government-Issued Photo ID #:
Expiry Date:	Expiry Date:
SIN #:	SIN #:
Profession:	Profession:
Company:	Company:
<input type="checkbox"/> End-User <input type="checkbox"/> Investor <input type="checkbox"/> Both	<input type="checkbox"/> End-User <input type="checkbox"/> Investor <input type="checkbox"/> Both

Cheques Payable to "LEVY ZAVET PC In Trust"

Broker Information: Fill in details or staple business card.	NOTES
Name: _____	_____
Brokerage: _____	_____
Email: _____	_____
Phone #: _____	_____

SUBMIT YOUR WORKSHEETS ONLINE TO RECEIVE A DIGITAL COPY AND FASTER

PROCESSING



1107 MAIN

HAMILTON

PLATINUM PRICE LIST

Model	Suite Type	View	Bathroom	Interior Size	Exterior Size	Total Size	Starting Price*	Lease Amount
A331	Studio	North	1	331	34	365	\$469,990	\$2,000
A383	Studio	West	1	383	91	474	\$499,990	\$2,200
B483	1 Bedroom	Southeast (C)	1	483	70	553	\$538,990	\$2,500
C507	1 Bedroom + Den	North	1	507	34	541	\$589,990	\$2,650
C482	1 Bedroom + Den	East	1	482	110	592	\$594,990	\$2,650
C518	1 Bedroom + Den	South (C)	1	518	51	569	\$605,990	\$2,650
C498	1 Bedroom + Den	West	1	498	91	589	\$614,990	\$2,700
B549	1 Bedroom	Southwest	1	549	131	680	\$623,990	\$2,700
D626	1 Bedroom + Den	South (C)	1.5	626	0	626	\$629,990	\$2,800
D599	1 Bedroom + Den	North	2	599	32	631	\$645,990	\$2,800
E613	2 Bedroom (I)	North	2	613	38	651	\$682,990	\$3,200
D574	1 Bedroom + Den	Northwest	2	574	84	658	\$684,990	\$2,900
E599	2 Bedroom (I)	West	2	599	51	650	\$691,990	\$3,200
E707	2 Bedroom (I)	West	2	707	42	749	\$695,990	\$3,200
E669	2 Bedroom	Northeast	2	669	0	669	\$714,990	\$3,300
E640	2 Bedroom (I)	South	2	640	51	691	\$714,990	\$3,300
F777	2 Bedroom + Den	East (C)	2	777	144	921	\$748,990	\$3,800
E765	2 Bedroom	Northwest	2	765	66	831	\$755,990	\$3,800
E789	2 Bedroom	North	2	792	53	845	\$769,990	\$3,800
E780	2 Bedroom	Northeast	2	780	51	831	\$778,990	\$3,800
E767	2 Bedroom	Southeast (C)	2	767	51	818	\$789,990	\$3,800

<p><u>Extended Deposit Structure</u> \$10,000 on Signing Balance to 5% in 15 days 5% in 180 days 5% on February 1, 2025 5% three months prior to Occupancy 5% (Payable to Levy Zavet PC in Trust)</p>	<p><u>Maintenance Fees</u> \$0.69/sqft on all suites</p> <p>Includes common elements, 16hr concierge M-F, 24hr concierge Sat-Sun, heating/cooling, gas, water, bulk internet. Excludes hydro.</p> <p>Parking Maintenance Fee: \$135.00/month Below Grade Locker Maintenance Fee: \$25.00/month Above Grade Locker Maintenance Fee: \$35.00/month Parking/Locker Combination Maintenance Fee: \$165.00/month Bicycle Storage Maintenance Fee: \$8.00/month</p>	<p><u>Standard Parking</u> \$65,000</p> <p><u>15 sqft Below Grade Locker</u> \$4,000</p> <p><u>45 sqft Above Grade Locker</u> \$6,000</p> <p><u>Parking/Locker Combination</u> \$75,000</p> <p><u>Bicycle Storage</u> \$500.00</p> <p><u>Occupancy Date</u> May, 2027</p> <p><u>Property Taxes</u> See City Posted Rates</p>
---	---	---

*Floor premiums range from \$1,000-\$20,000 **Availability, features, promotions, and prices are subject to change without notice.
 Some conditions apply. Please consult an RDS Sales Representative for details.





NORTH

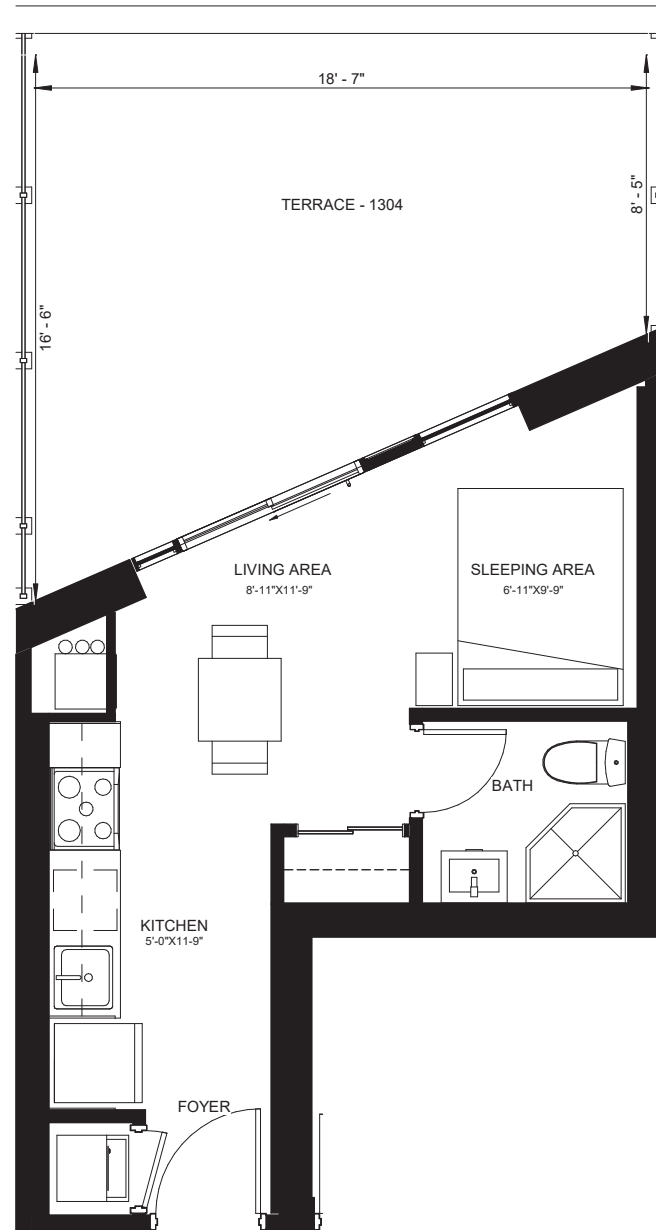
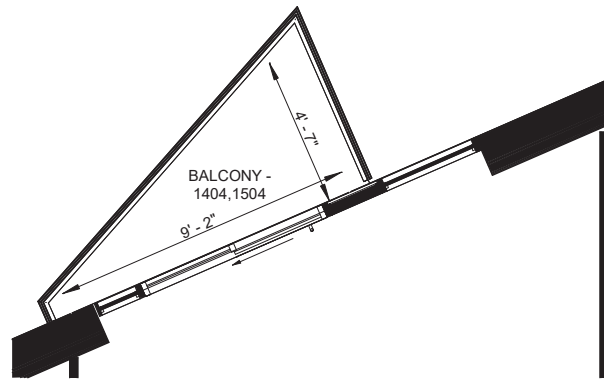

LEVEL 13-15

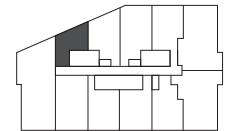

1107
MAIN
HAMILTON

STUDIO

A331

SUITE: 331 SQ.FT. TERRACE: 271 SQ.FT. TOTAL: 602 SQ.FT. | UNIT: #1304

SUITE: 331 SQ.FT. BALCONY: 34 SQ.FT. TOTAL: 375 SQ.FT. | UNITS: #1404, 1504

IN8

Illustrations are concept only. Plans and specifications are subject to change without notice. Actual floor space may vary from stated floor area. See sales representative for more information. E. & O. E.



NORTH

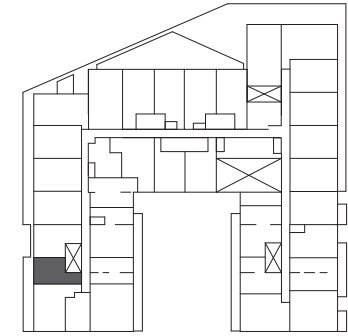
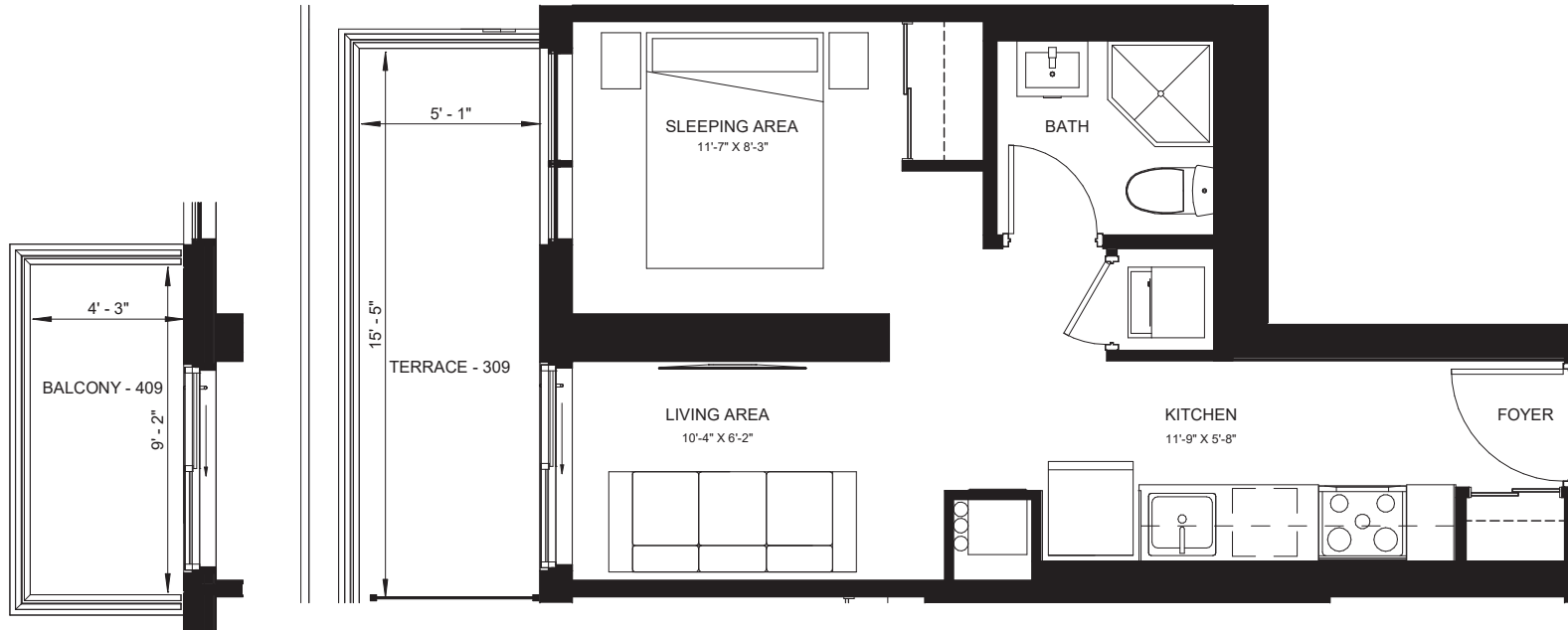

LEVEL 3

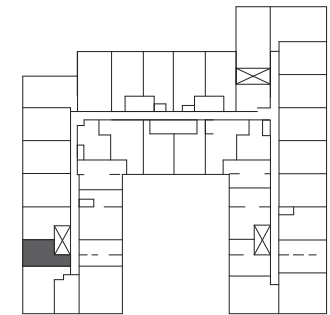

LEVEL 4

STUDIO

A383

SUITE: 383 SQ.FT. TERRACE: 91 SQ.FT. TOTAL: 474 SQ.FT. | UNIT: #309

SUITE: 383 SQ.FT. BALCONY: 51 SQ.FT. TOTAL: 434 SQ.FT. | UNIT: #409

IN8

1107
MAIN
HAMILTON

Illustrations are concept only. Plans and specifications are subject to change without notice. Actual floor space may vary from stated floor area. See sales representative for more information. E. & O. E.



NORTH

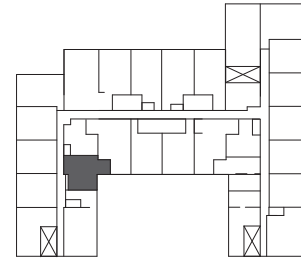
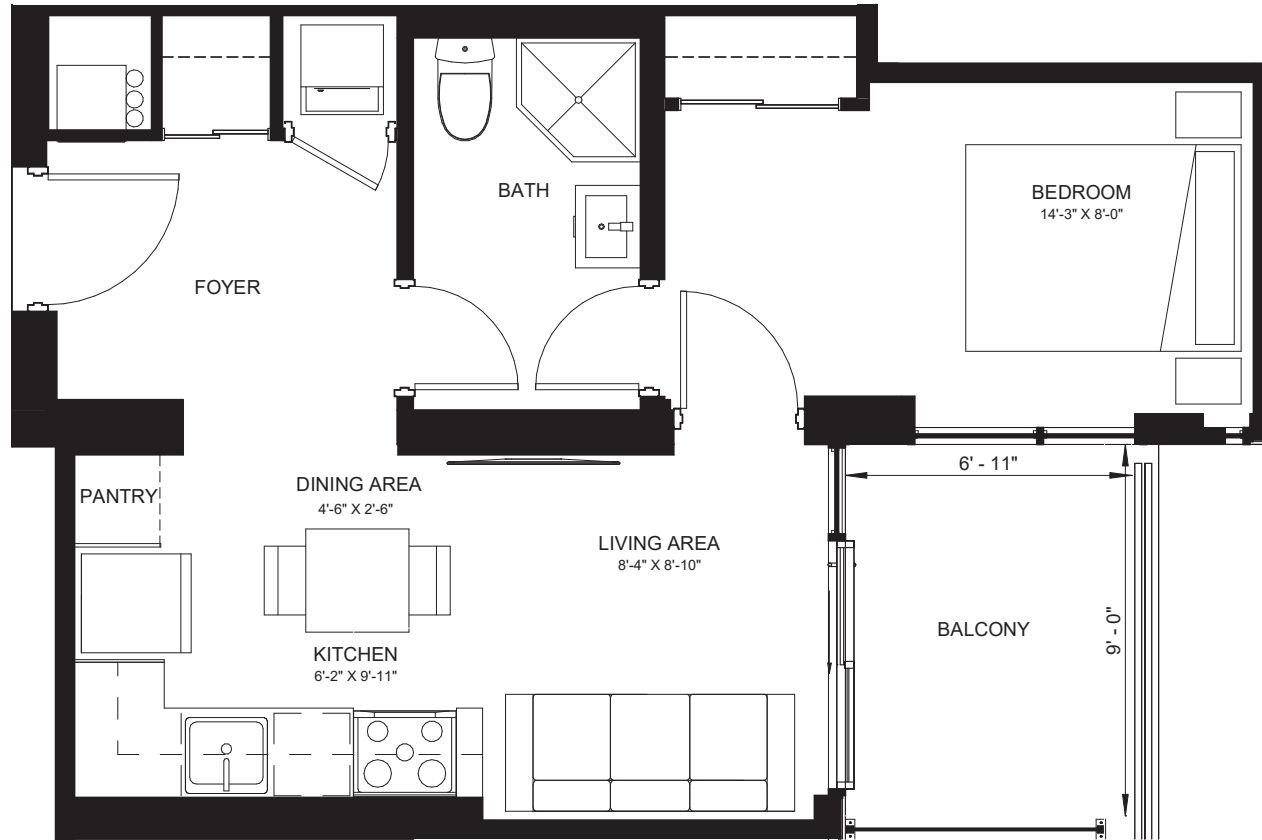

1 BED

B483

SUITE: 483 SQ.FT.

BALCONY: 70 SQ.FT.

TOTAL: 553 SQ.FT. |

UNITS: #603, 703

IN8

**1107
MAIN**
HAMILTON

Illustrations are concept only. Plans and specifications are subject to change without notice. Actual floor space may vary from stated floor area. See sales representative for more information. E. & O. E.



NORTH

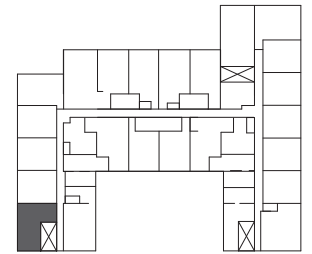
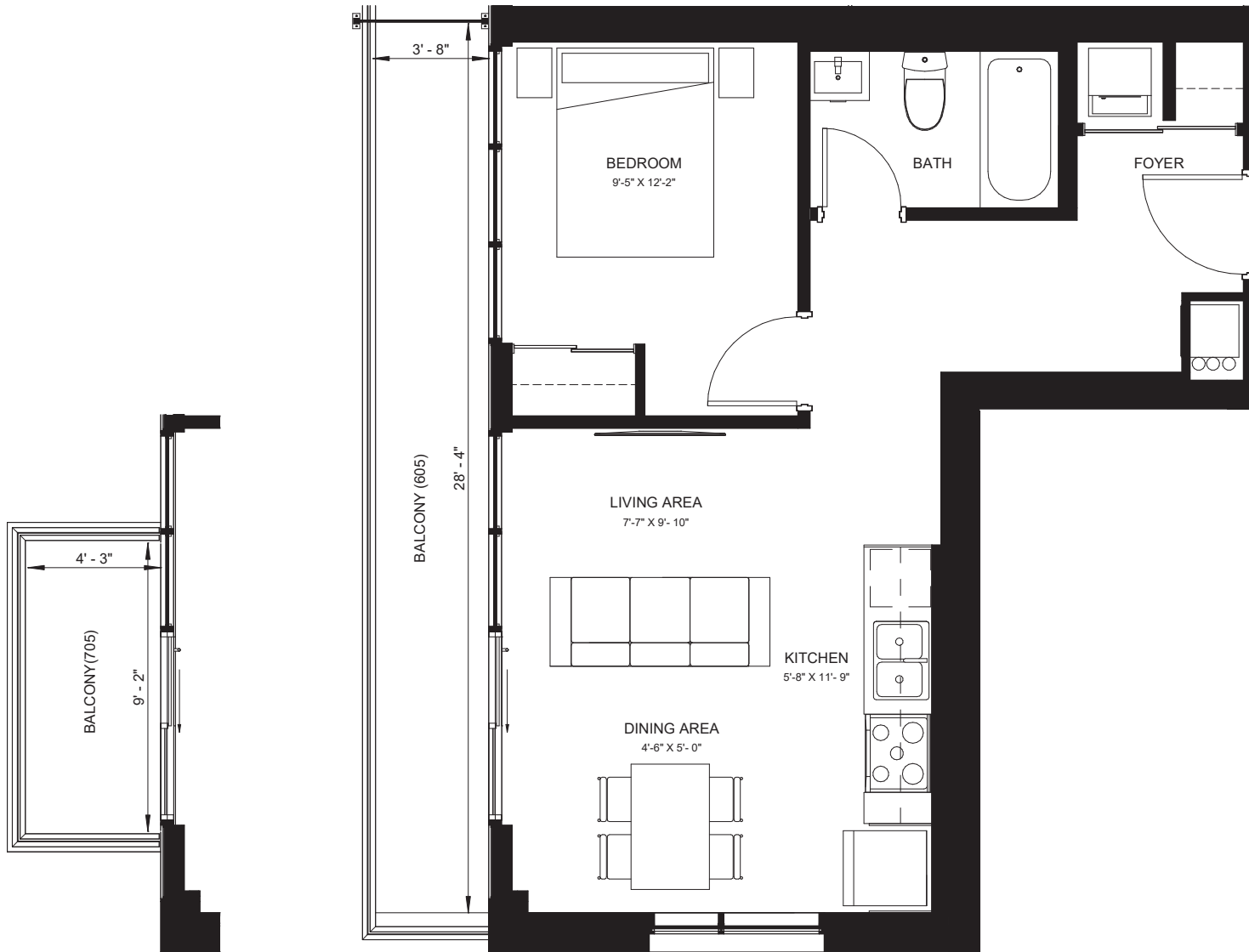

LEVEL 6-7

**1107
MAIN**
HAMILTON

1 BED

B549

SUITE: 549 SQ.FT. **TERRACE:** 131 SQ.FT. **TOTAL:** 680 SQ.FT. | **UNIT:** #605

SUITE: 549 SQ.FT. **BALCONY:** 51 SQ.FT. **TOTAL:** 600 SQ.FT. | **UNIT:** #705

IN8

Illustrations are concept only. Plans and specifications are subject to change without notice. Actual floor space may vary from stated floor area. See sales representative for more information. E. & O. E.



NORTH

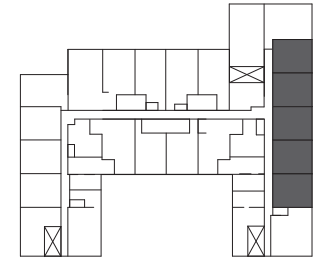
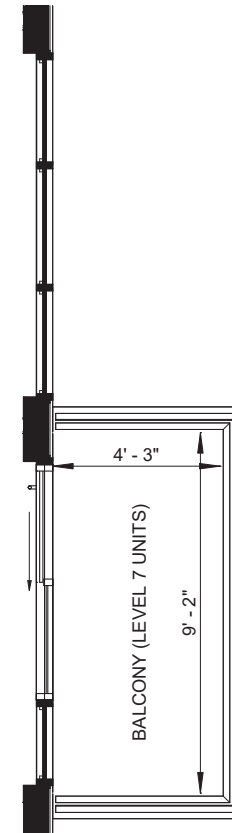
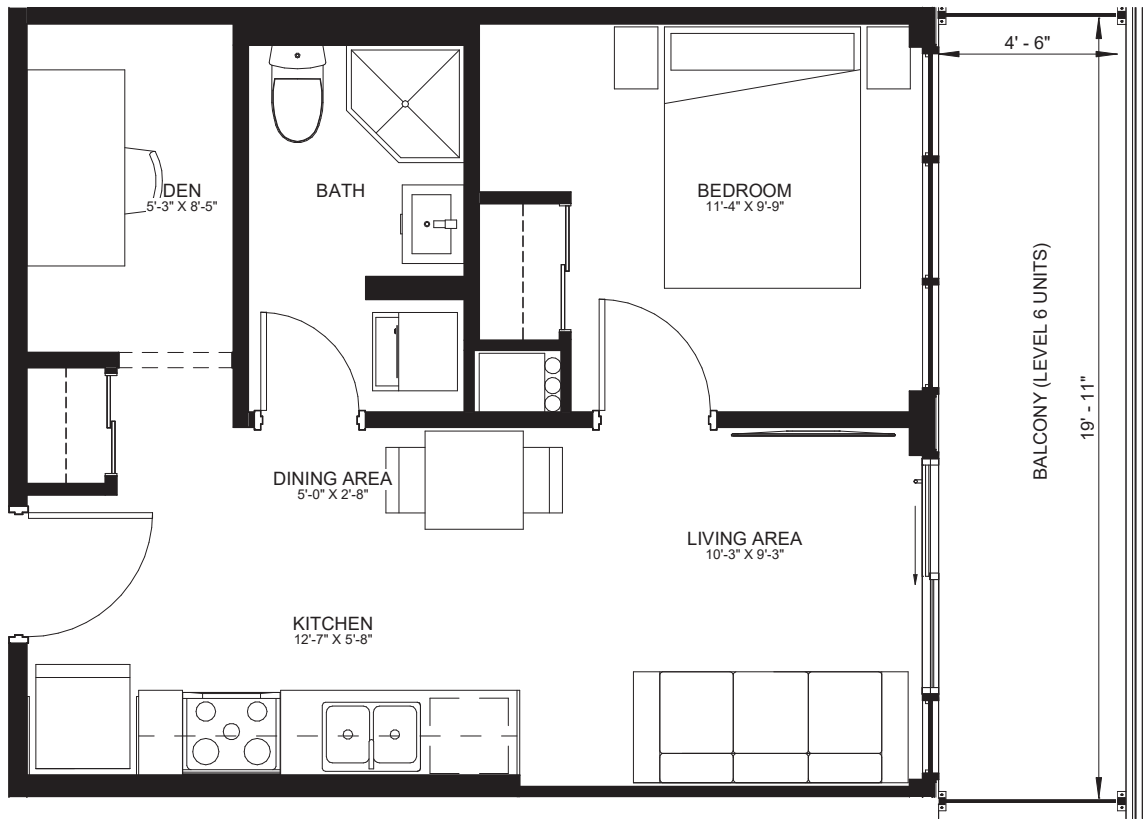

LEVEL 6 & 7

1107
MAIN
HAMILTON

1 BED + DEN

C482

SUITE: 482 SQ.FT. TERRACE: 110 SQ.FT. TOTAL: 592 SQ.FT. | UNITS: #617-621

SUITE: 482 SQ.FT. BALCONY: 51 SQ.FT. TOTAL: 533 SQ.FT. | UNITS: #717-721

IN8

Illustrations are concept only. Plans and specifications are subject to change without notice. Actual floor space may vary from stated floor area. See sales representative for more information. E. & O. E.



NORTH

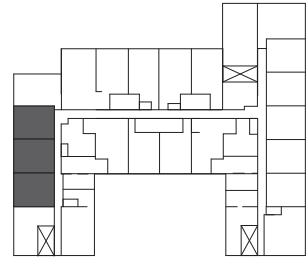
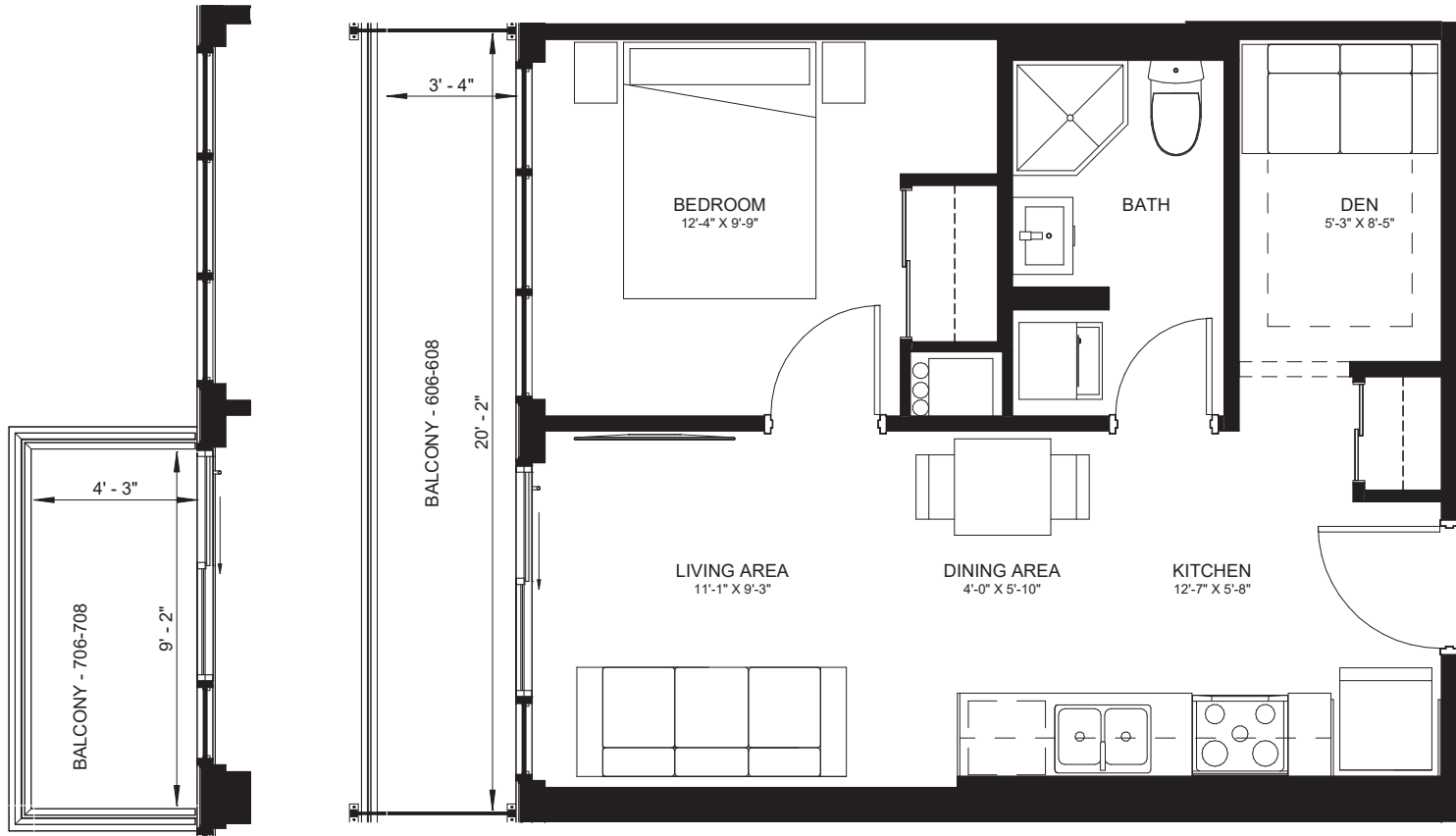

LEVEL 6-7

1 BED + DEN

**1107
MAIN**
HAMILTON

C498

SUITE: 498 SQ.FT. BALCONY: 91 SQ.FT. TOTAL: 589 SQ.FT. | UNITS: #606-608

SUITE: 498 SQ.FT. BALCONY: 52 SQ.FT. TOTAL: 550 SQ.FT. | UNITS: #706-708

IN8

Illustrations are concept only. Plans and specifications are subject to change without notice. Actual floor space may vary from stated floor area. See sales representative for more information. E. & O. E.



NORTH

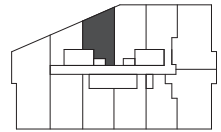
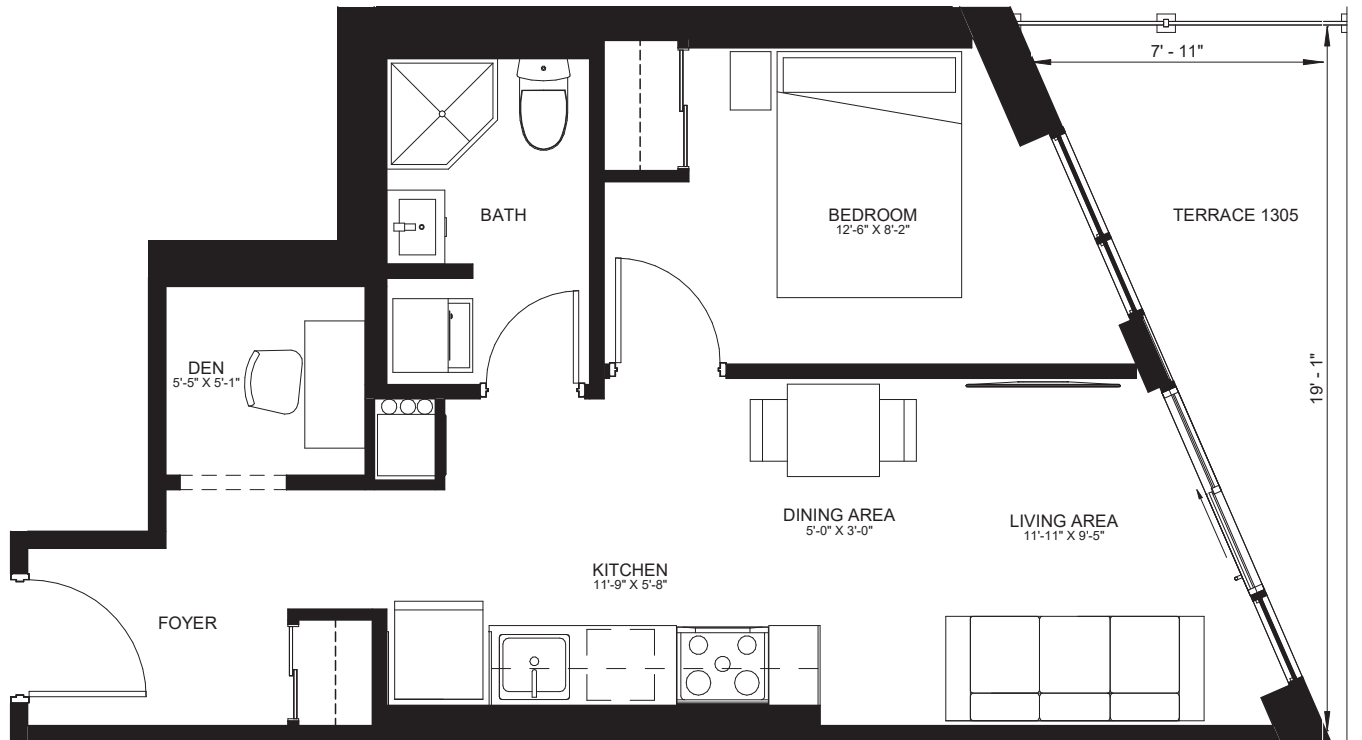

LEVEL 13-15

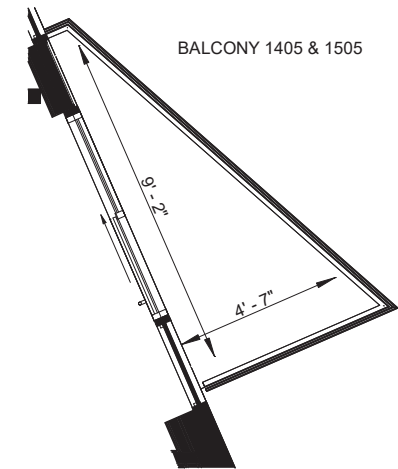

1107
MAIN
HAMILTON

1 BED + DEN

C507

SUITE: 507 SQ.FT.

TERRACE: 115 SQ.FT.

TOTAL: 622 SQ.FT.

UNIT: #1305

SUITE: 507 SQ.FT.

BALCONY: 34 SQ.FT.

TOTAL: 541 SQ.FT.

UNITS: #1405, 1505

IN8

Illustrations are concept only. Plans and specifications are subject to change without notice. Actual floor space may vary from stated floor area. See sales representative for more information. E. & O. E.



NORTH

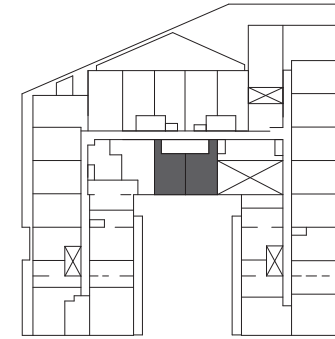
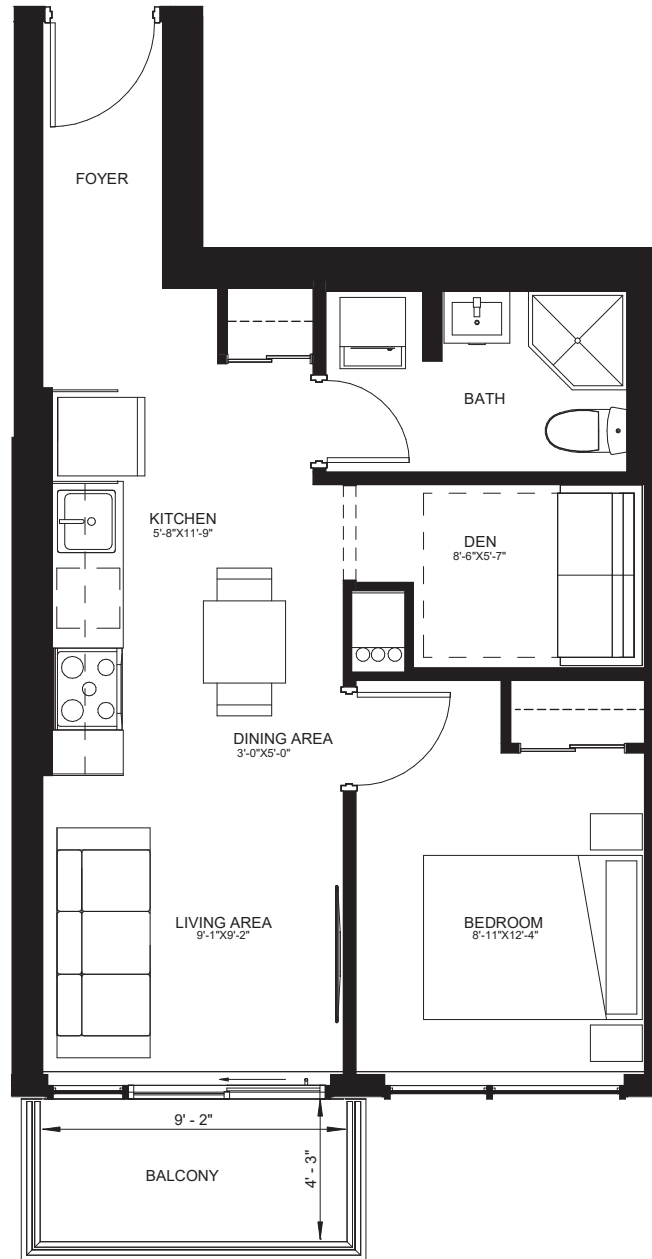

LEVEL 3

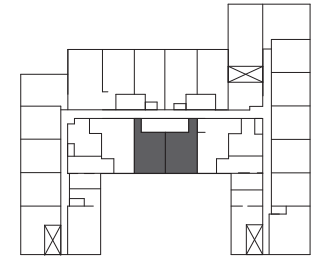

LEVEL 6-7

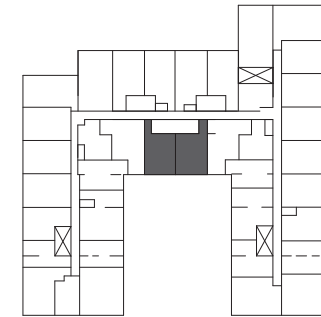

LEVEL 4

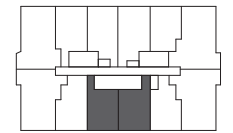

LEVEL 8-12

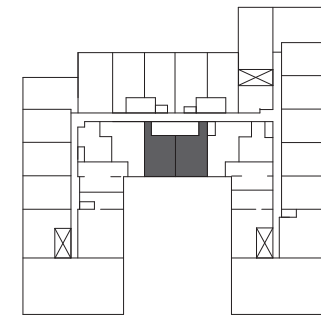

LEVEL 5

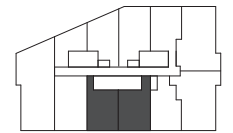

LEVEL 13-15

1 BED + DEN

C518

SUITE: 518 SQ.FT.

BALCONY: 51 SQ.FT.

TOTAL: 569 SQ.FT.

UNITS: #301-1501, 333, 435, 526-726

SUITE: 521 SQ.FT.

BALCONY: 51 SQ.FT.

TOTAL: 572 SQ.FT.

UNITS: #912-1212

SUITE: 522 SQ.FT.

BALCONY: 51 SQ.FT.

TOTAL: 573 SQ.FT.

UNITS: #812, 1311-1511

1107
MAIN
HAMILTON

IN8

Illustrations are concept only. Plans and specifications are subject to change without notice. Actual floor space may vary from stated floor area. See sales representative for more information. E. & O. E.



NORTH

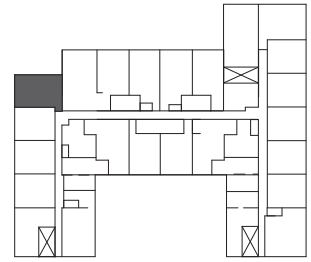
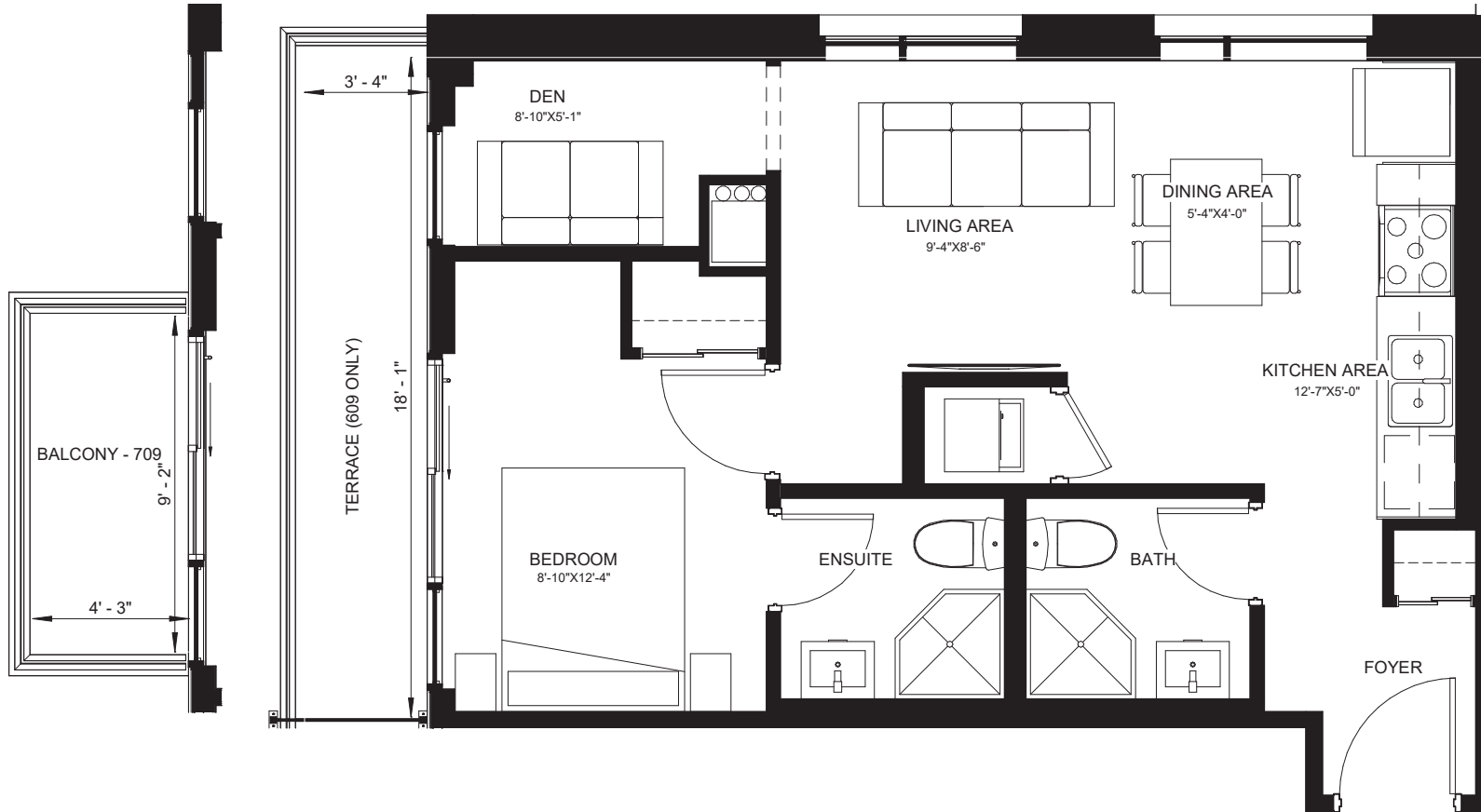

LEVEL 6-7

**1107
MAIN**
HAMILTON

1 BED + DEN

D574

SUITE: 574 SQ.FT.

TERRACE: 84 SQ.FT.

TOTAL: 658 SQ.FT. | UNIT: #609

SUITE: 574 SQ.FT.

BALCONY: 51 SQ.FT.

TOTAL: 625 SQ.FT. | UNIT: #709

IN8

Illustrations are concept only. Plans and specifications are subject to change without notice. Actual floor space may vary from stated floor area. See sales representative for more information. E. & O. E.



NORTH

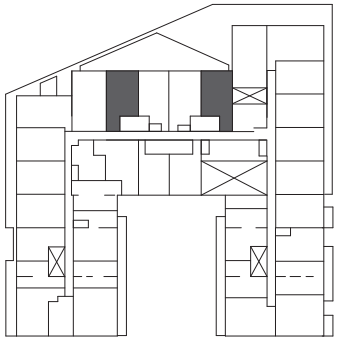

LEVEL 3

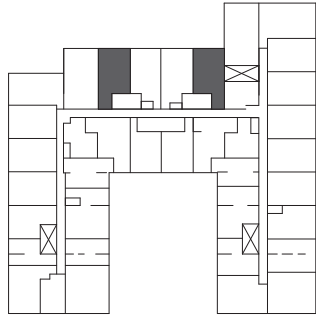

LEVEL 4

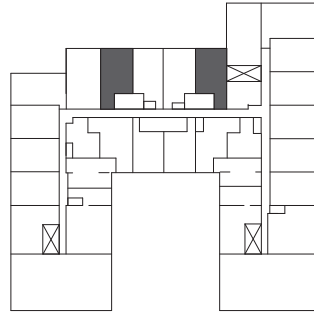

LEVEL 5

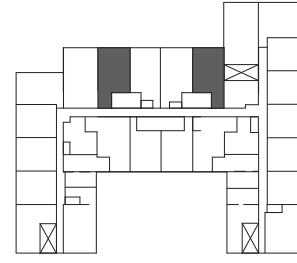

LEVEL 6-7

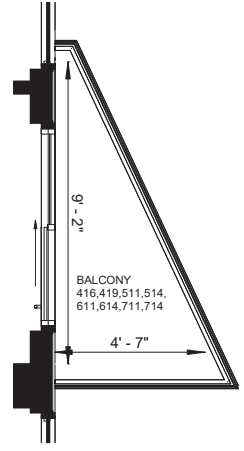
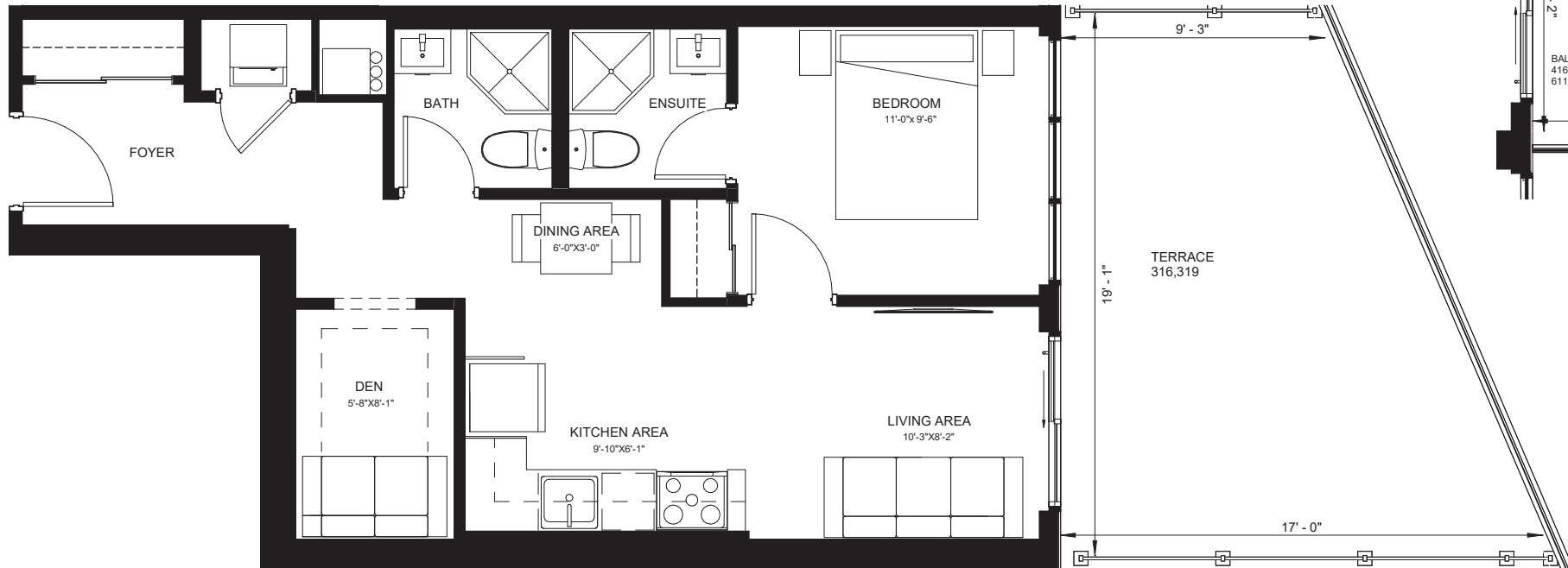

1 BED + DEN

**1107
MAIN**
HAMILTON

D599

SUITE: 599 SQ.FT.

SUITE: 599 SQ.FT.

SUITE: 598 SQ.FT.

TERRACE: 133 SQ.FT.

BALCONY: 32 SQ.FT.

BALCONY: 32 SQ.FT.

TOTAL: 732 SQ.FT.

TOTAL: 631 SQ.FT.

TOTAL: 630 SQ.FT.

UNITS: #316, 319

UNITS: #416, 511-711

UNITS: #419, 514-714

IN8

Illustrations are concept only. Plans and specifications are subject to change without notice. Actual floor space may vary from stated floor area. See sales representative for more information. E. & O. E.



NORTH

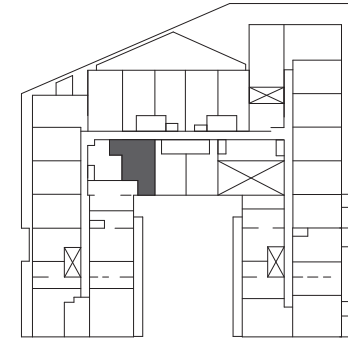
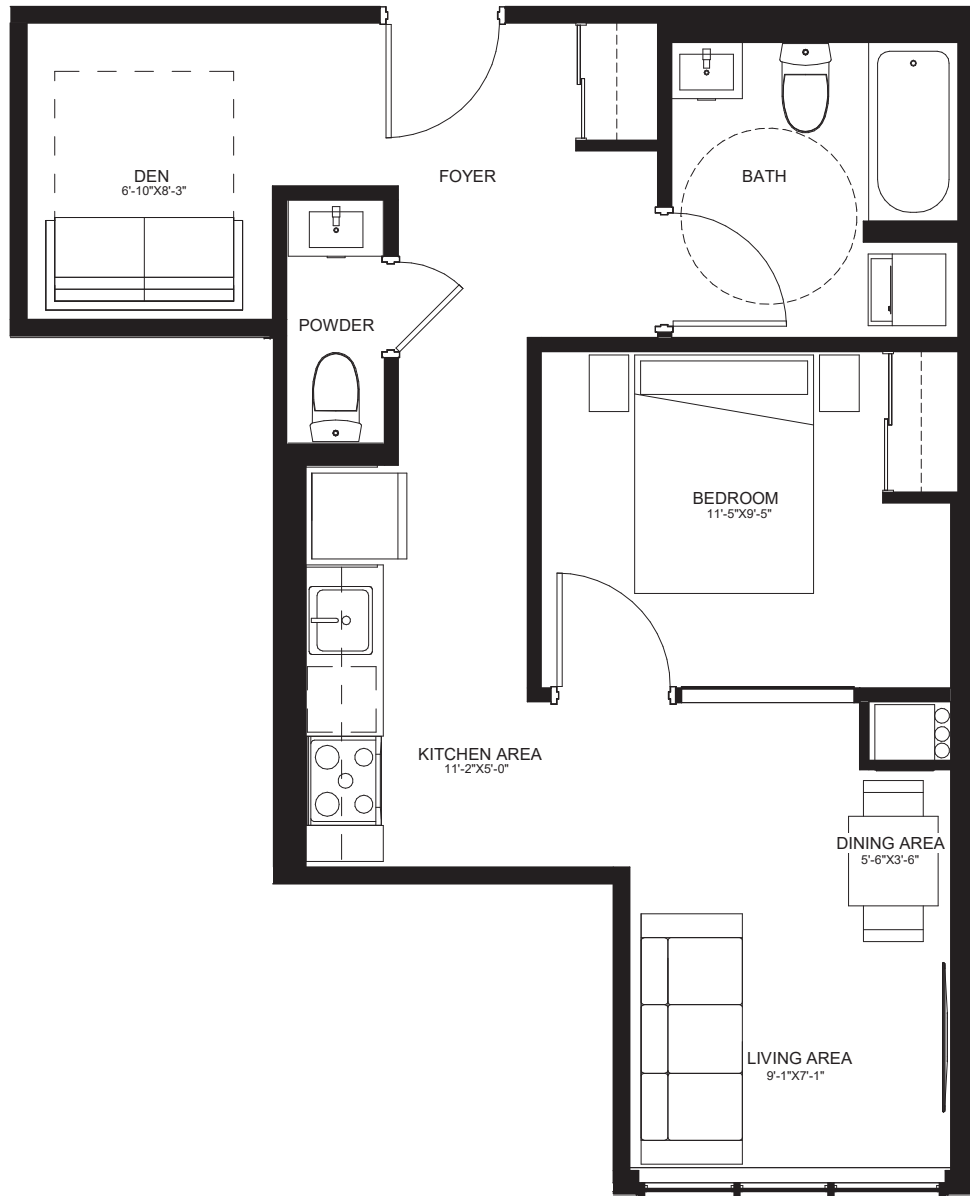

LEVEL 3-4

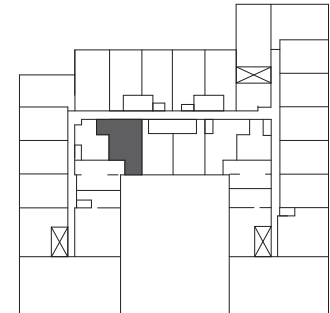

LEVEL 5

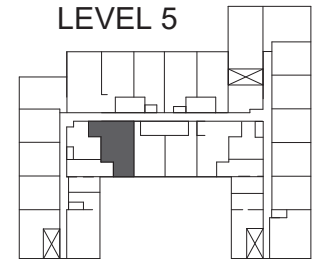

LEVEL 6-7

1 BED + DEN

D626

SUITE: 626 SQ.FT. | UNITS: #302, 502, 702

SUITE: 627 SQ.FT. | UNITS: #402, 602

1107
MAIN
HAMILTON

IN8

Illustrations are concept only. Plans and specifications are subject to change without notice. Actual floor space may vary from stated floor area. See sales representative for more information. E. & O. E.



NORTH

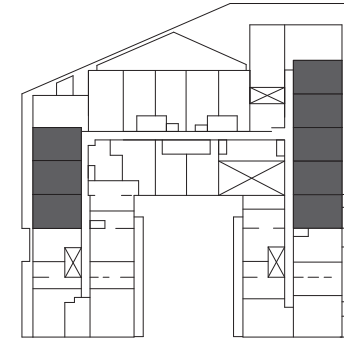
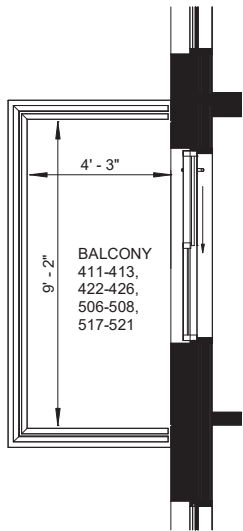

LEVEL 3

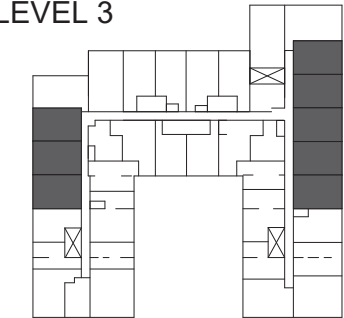

LEVEL 4

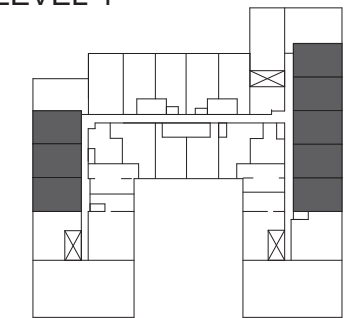

LEVEL 5

2 BED

E599

SUITE: 599 SQ.FT.

TERRACE: 113 SQ.FT.

TOTAL: 712 SQ.FT.

UNITS: #311-313, 322-326

SUITE: 599 SQ.FT.

BALCONY: 51 SQ.FT.

TOTAL: 650 SQ.FT.

UNITS: #411-413, 422-426, 506-508, 517-521

IN8

1107
MAIN
HAMILTON

Illustrations are concept only. Plans and specifications are subject to change without notice. Actual floor space may vary from stated floor area. See sales representative for more information. E. & O. E.



NORTH

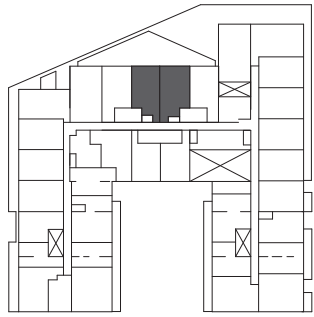

LEVEL 3-4

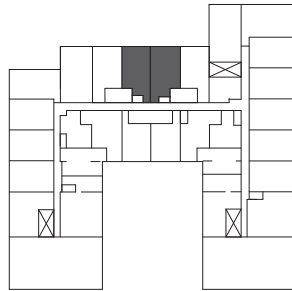

LEVEL 5

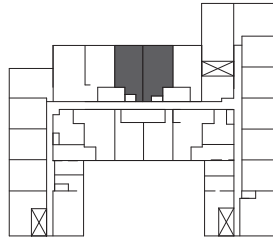

LEVEL 6-7

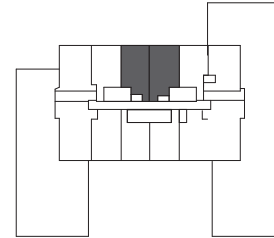

LEVEL 8

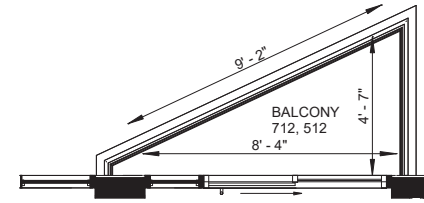

BALCONY
712, 512

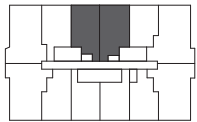

LEVEL 9-12

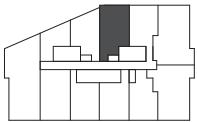

LEVEL 13-15

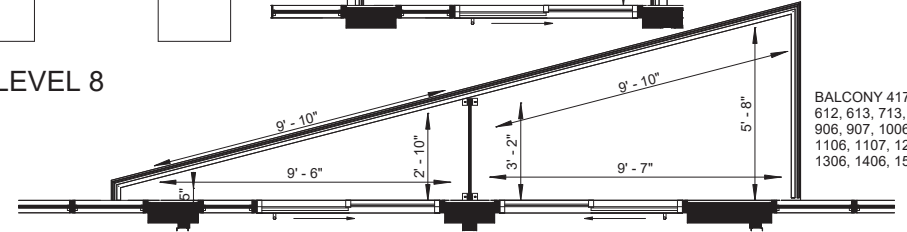

BALCONY 417, 418, 513,
612, 613, 713, 806, 807,
906, 907, 1006, 1007,
1106, 1107, 1206, 1207,
1306, 1406, 1506

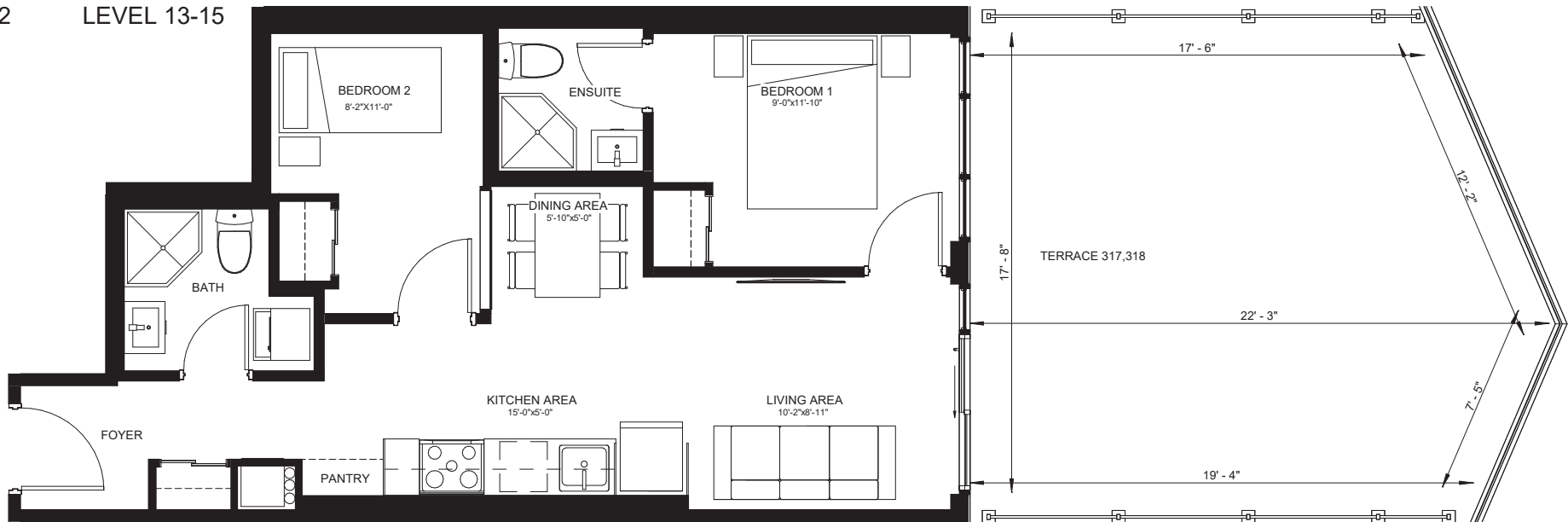

2 BED

E613

SUITE: 613 SQ.FT.
SUITE: 613 SQ.FT.
SUITE: 614 SQ.FT.
SUITE: 615 SQ.FT.
SUITE: 616 SQ.FT.

TERRACE: 304 SQ.FT.
BALCONY: 38 SQ.FT.
BALCONY: 24 SQ.FT.
BALCONY: 43 SQ.FT.
BALCONY: 25 SQ.FT.

TOTAL: 917 SQ.FT. | UNITS: #317, 318
TOTAL: 651 SQ.FT. | UNITS: #512, 1306-1506
TOTAL: 638 SQ.FT. | UNITS: #612, 712, 806-1206
TOTAL: 658 SQ.FT. | UNITS: #613, 713, 807-1207
TOTAL: 641 SQ.FT. | UNITS: #418, 513

IN8

1107
MAIN
HAMILTON

Illustrations are concept only. Plans and specifications are subject to change without notice. Actual floor space may vary from stated floor area. See sales representative for more information. E. & O. E.



NORTH

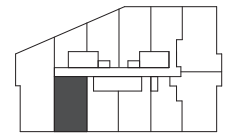
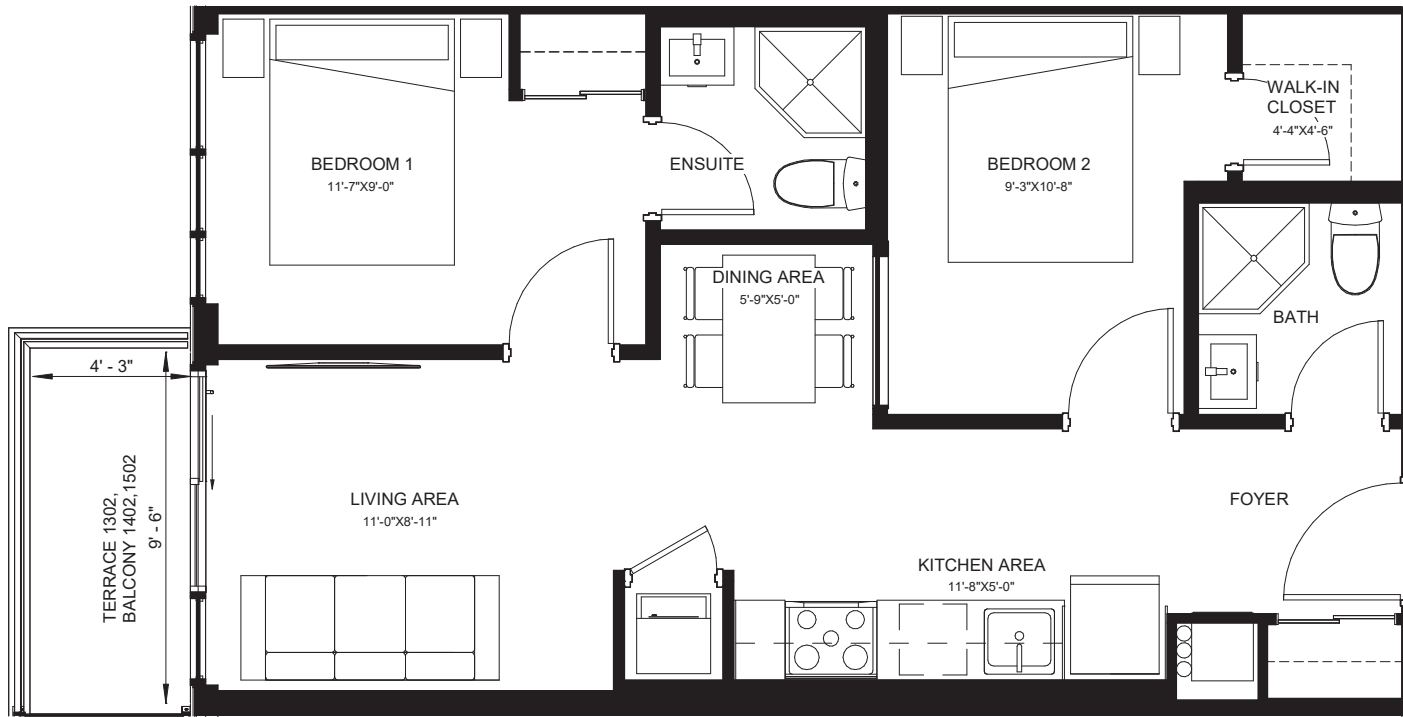

LEVEL 13-15

**1107
MAIN**
HAMILTON

2 BED

E640

SUITE: 640 SQ.FT.

TERRACE: 51 SQ.FT.

TOTAL: 691 SQ.FT. | UNIT: #1302

SUITE: 640 SQ.FT.

BALCONY: 51 SQ.FT.

TOTAL: 691 SQ.FT. | UNITS: #1402, 1502

IN8

Illustrations are concept only. Plans and specifications are subject to change without notice. Actual floor space may vary from stated floor area. See sales representative for more information. E. & O. E.



NORTH

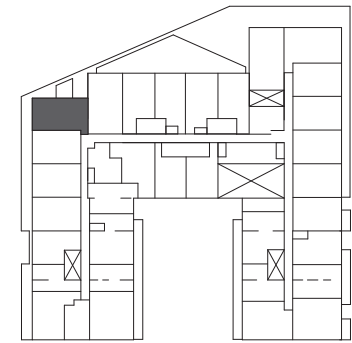

LEVEL 3

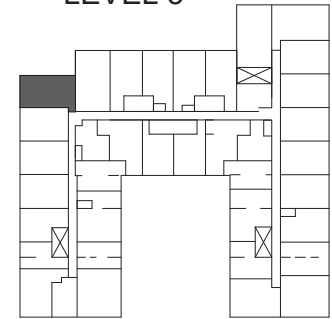

LEVEL 4

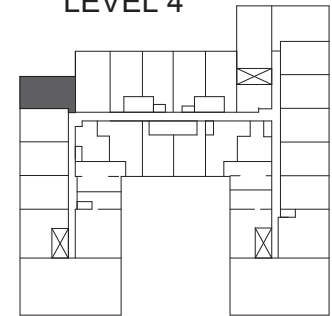

LEVEL 5

2 BED

E669

SUITE: 669 SQ.FT. TERRACE: 98 SQ.FT. TOTAL: 767 SQ.FT. | UNIT: #314

SUITE: 669 SQ.FT. | UNITS: #414, 509

IN8

1107
MAIN
HAMILTON

Illustrations are concept only. Plans and specifications are subject to change without notice. Actual floor space may vary from stated floor area. See sales representative for more information. E. & O. E.



NORTH

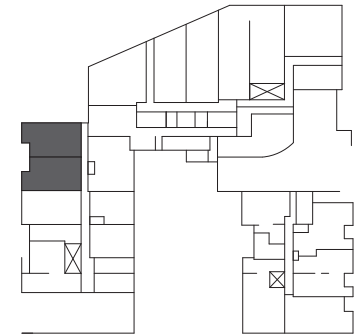
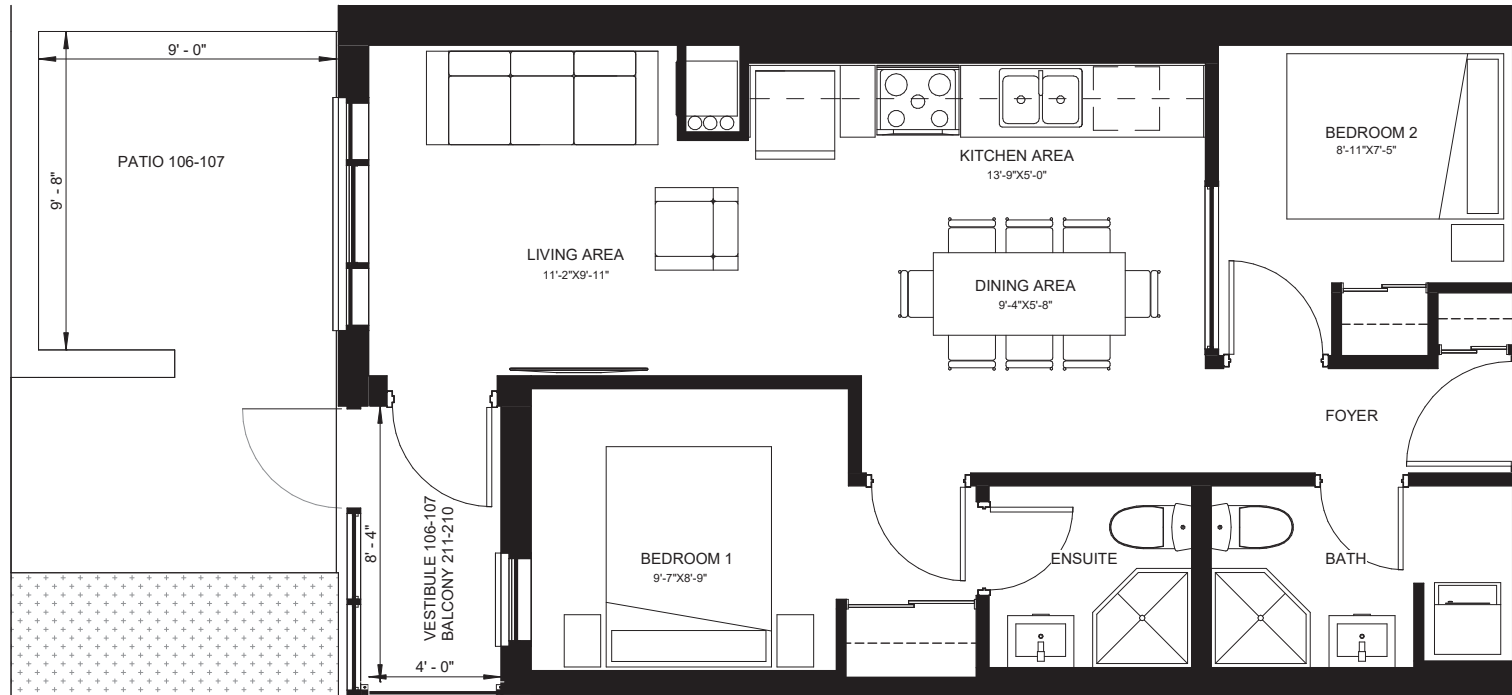

LEVEL 1

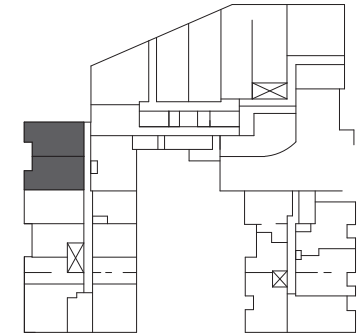

LEVEL 2

2 BED

E707

SUITE: 707 SQ.FT. PATIO: 111 SQ.FT. TOTAL: 818 SQ.FT. | UNIT: #107
SUITE: 689 SQ.FT. PATIO: 102 SQ.FT. TOTAL: 791 SQ.FT. | UNIT: #106
SUITE: 707 SQ.FT. BALCONY: 42 SQ.FT. TOTAL: 749 SQ.FT. | UNIT: #211
SUITE: 689 SQ.FT. BALCONY: 42 SQ.FT. TOTAL: 731 SQ.FT. | UNIT: #210

Illustrations are concept only. Plans and specifications are subject to change without notice. Actual floor space may vary from stated floor area. See sales representative for more information. E. & O. E.

**1107
MAIN**
HAMILTON

IN8



NORTH

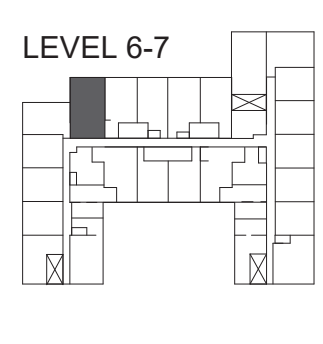
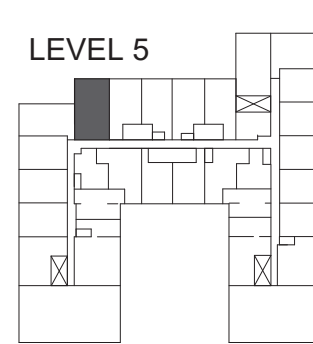
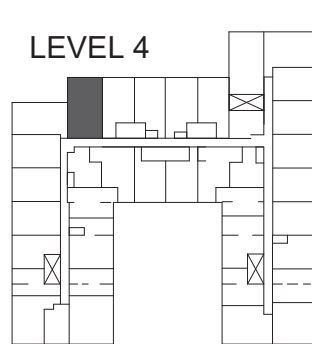
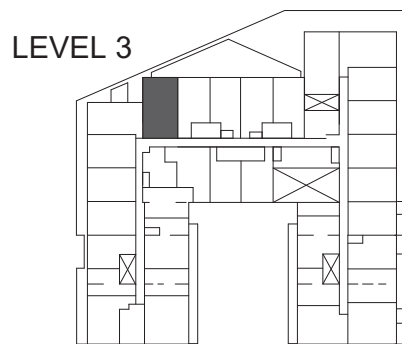
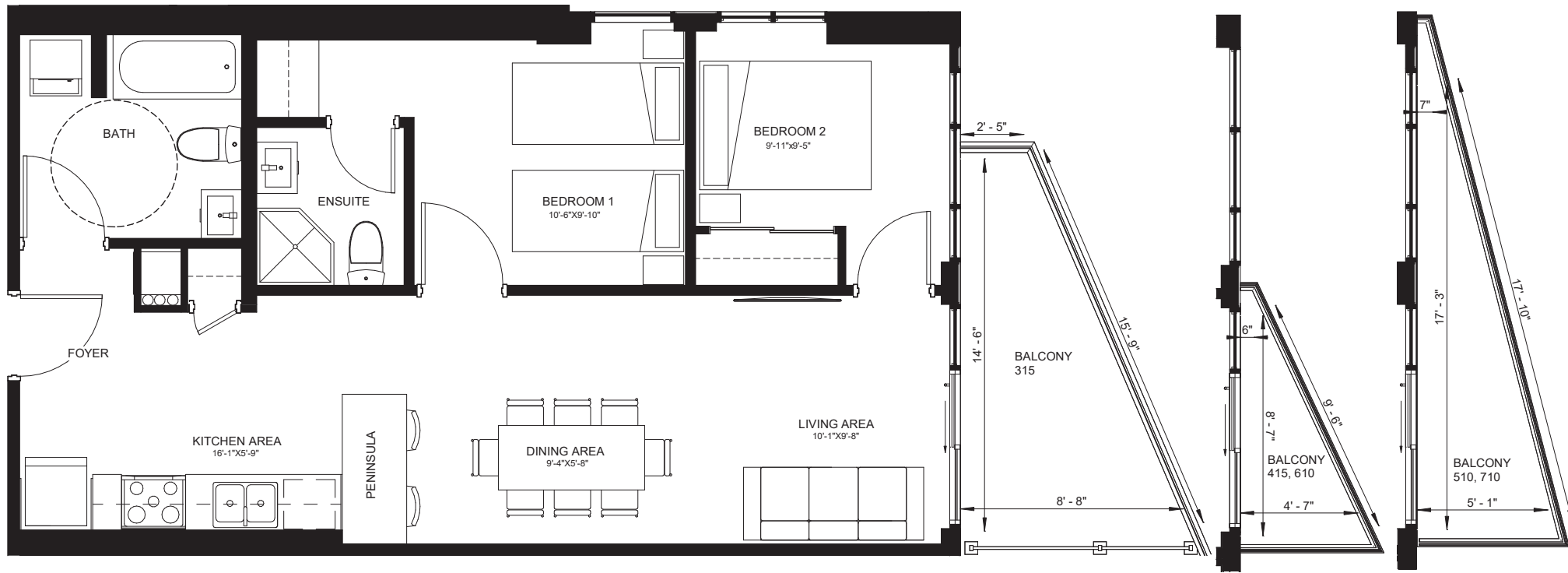

**1107
MAIN**
HAMILTON

2 BED

E765

SUITE: 765 SQ.FT.
SUITE: 765 SQ.FT.
SUITE: 765 SQ.FT.
SUITE: 774 SQ.FT.

BALCONY: 99 SQ.FT.
BALCONY: 32 SQ.FT.
BALCONY: 66 SQ.FT.
BALCONY: 66 SQ.FT.

TOTAL: 864 SQ.FT. | UNIT: #315
TOTAL: 797 SQ.FT. | UNITS: #415, 610
TOTAL: 831 SQ.FT. | UNIT: #510
TOTAL: 840 SQ.FT. | UNIT: #710

IN8

Illustrations are concept only. Plans and specifications are subject to change without notice. Actual floor space may vary from stated floor area. See sales representative for more information. E. & O. E.



NORTH

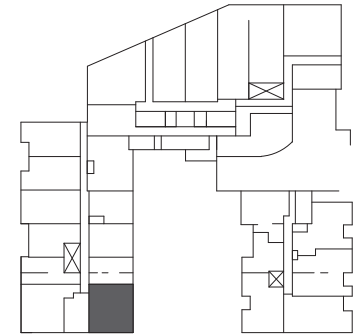
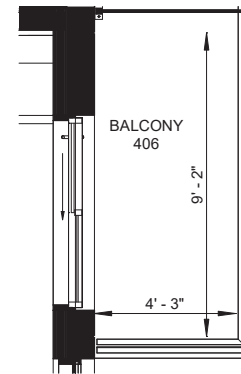
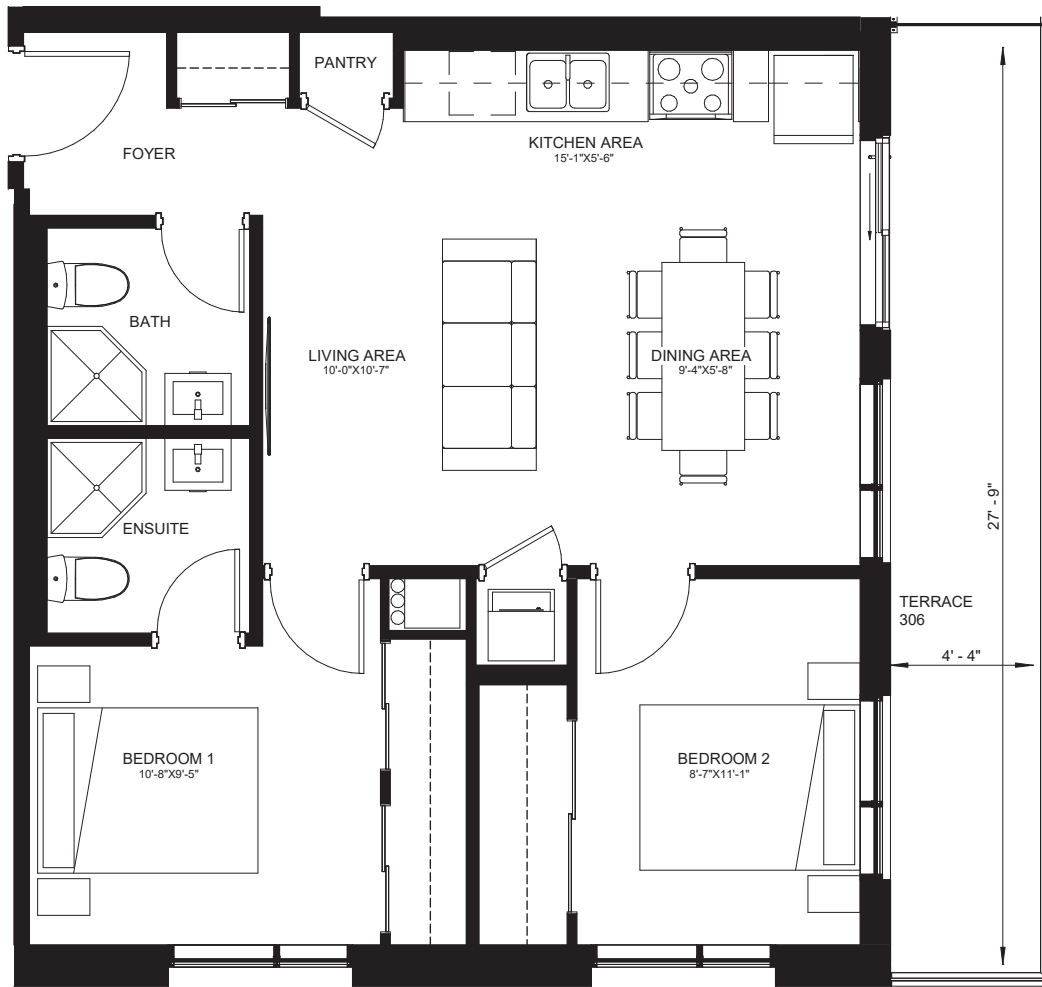

LEVEL 2

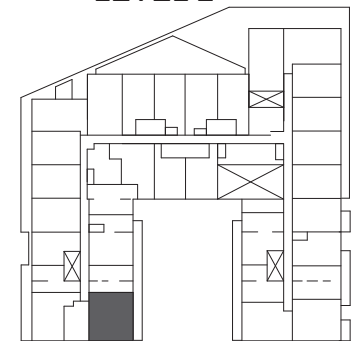

LEVEL 3-4

**1107
MAIN**
HAMILTON

2 BED

E767

SUITE: 767 SQ.FT. | TERRACE: 144 SQ.FT. | TOTAL: 911 SQ.FT. | UNIT: #306

SUITE: 767 SQ.FT. | UNIT: #204

SUITE: 767 SQ.FT. | BALCONY: 51 SQ.FT. | TOTAL: 818 SQ.FT. | UNIT: #406

IN8

Illustrations are concept only. Plans and specifications are subject to change without notice. Actual floor space may vary from stated floor area. See sales representative for more information. E. & O. E.



NORTH

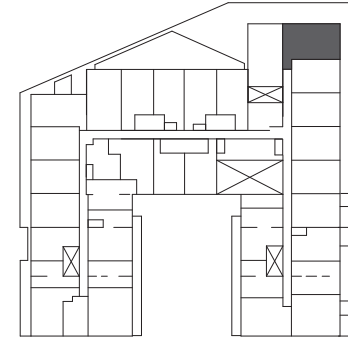
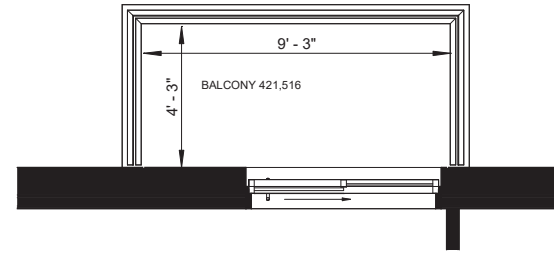

LEVEL 3

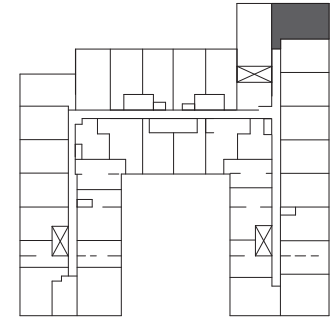

LEVEL 4

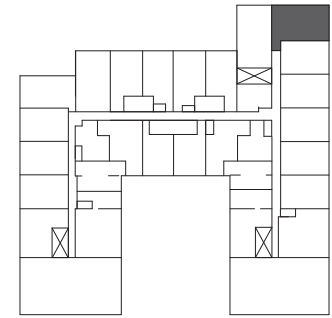

LEVEL 5

2 BED

E780

SUITE: 780 SQ.FT. TERRACE: 207 SQ.FT. TOTAL: 1049 SQ.FT. | UNIT: #321

SUITE: 780 SQ.FT. BALCONY: 51 SQ.FT. TOTAL: 804 SQ.FT. | UNITS: #421, 516

1107
MAIN
HAMILTON

IN8

Illustrations are concept only. Plans and specifications are subject to change without notice. Actual floor space may vary from stated floor area. See sales representative for more information. E. & O. E.

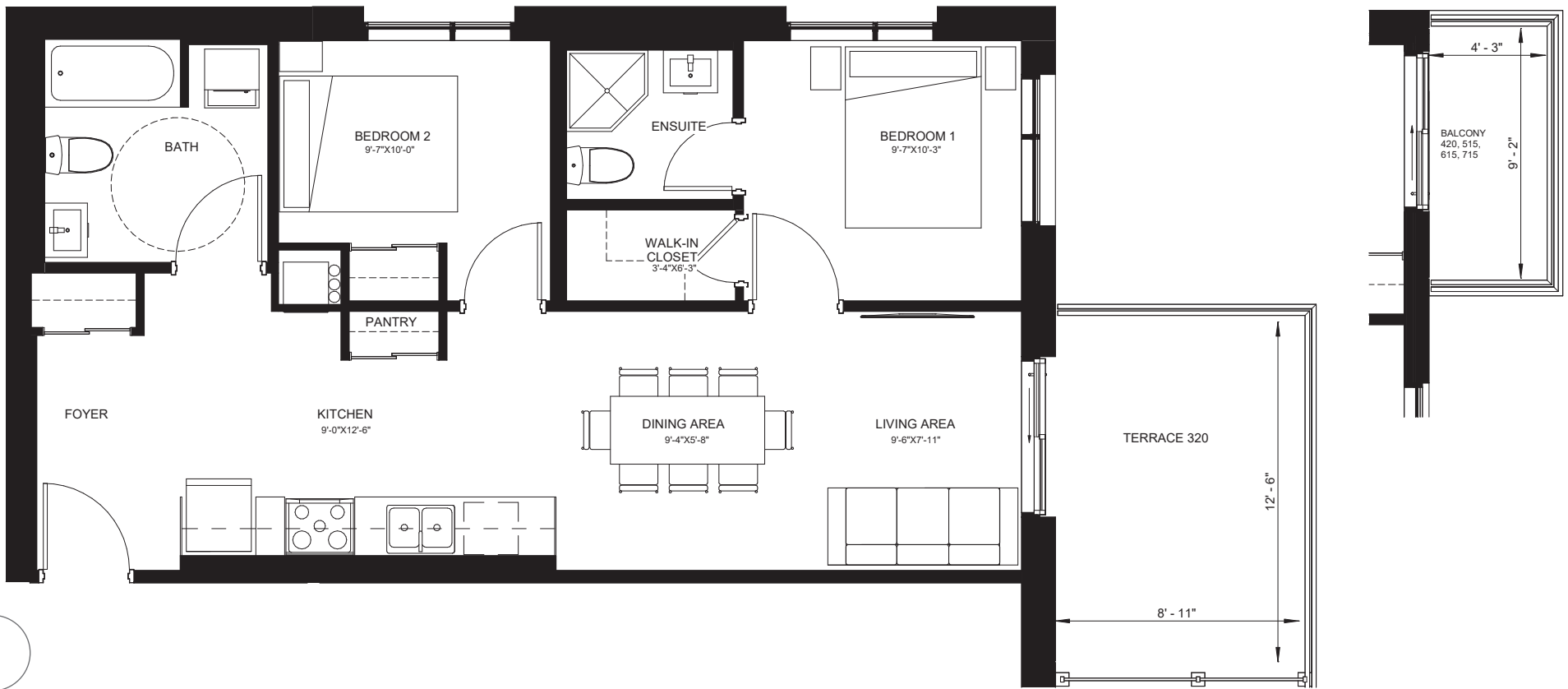

NORTH

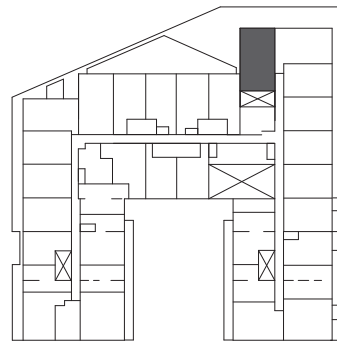

LEVEL 3-4

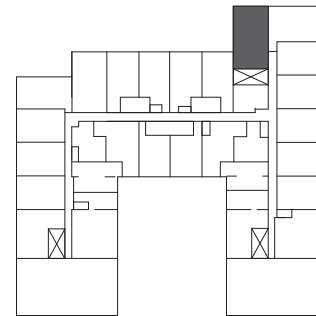

LEVEL 5

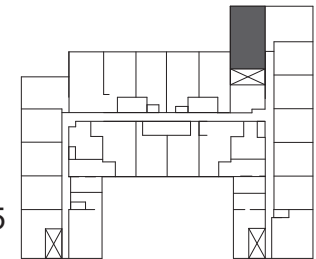

LEVEL 6-7

2 BED

E789

SUITE: 789 SQ.FT. | TERRACE: 132 SQ.FT. | TOTAL: 921 SQ.FT. | UNIT: #320

SUITE: 792 SQ.FT. | BALCONY: 53 SQ.FT. | TOTAL: 845 SQ.FT. | UNITS: #420, 515-715

IN8

Illustrations are concept only. Plans and specifications are subject to change without notice. Actual floor space may vary from stated floor area. See sales representative for more information. E. & O. E.

**1107
MAIN**
HAMILTON



NORTH

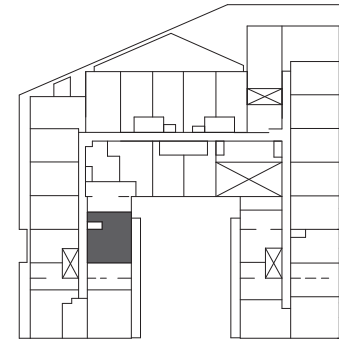
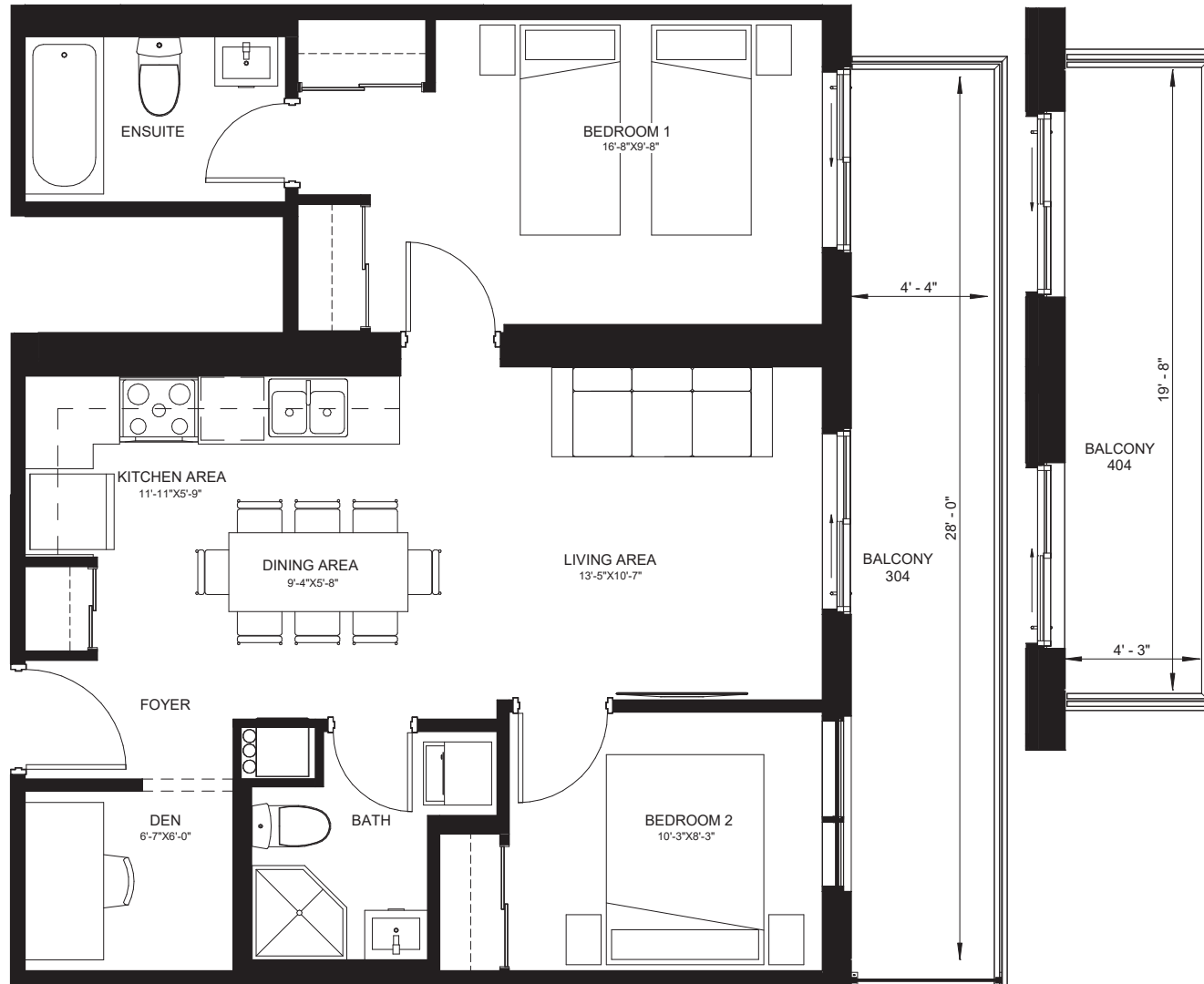

LEVEL 3

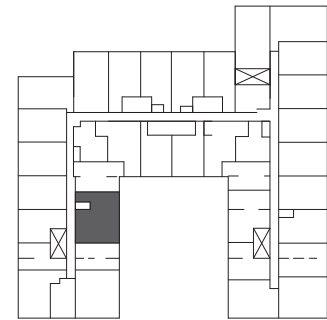

LEVEL 4

2 BED

F777

SUITE: 777 SQ.FT. BALCONY: 144 SQ.FT. TOTAL: 1034 SQ.FT. | UNIT: #304

SUITE: 777 SQ.FT. BALCONY: 51 SQ.FT. TOTAL: 1033 SQ.FT. | UNIT: #404

IN8

**1107
MAIN**
HAMILTON

Illustrations are concept only. Plans and specifications are subject to change without notice. Actual floor space may vary from stated floor area. See sales representative for more information. E. & O. E.

FLOOR 2

STUDIO
 1 BED
 1 BED + DEN
 2 BED

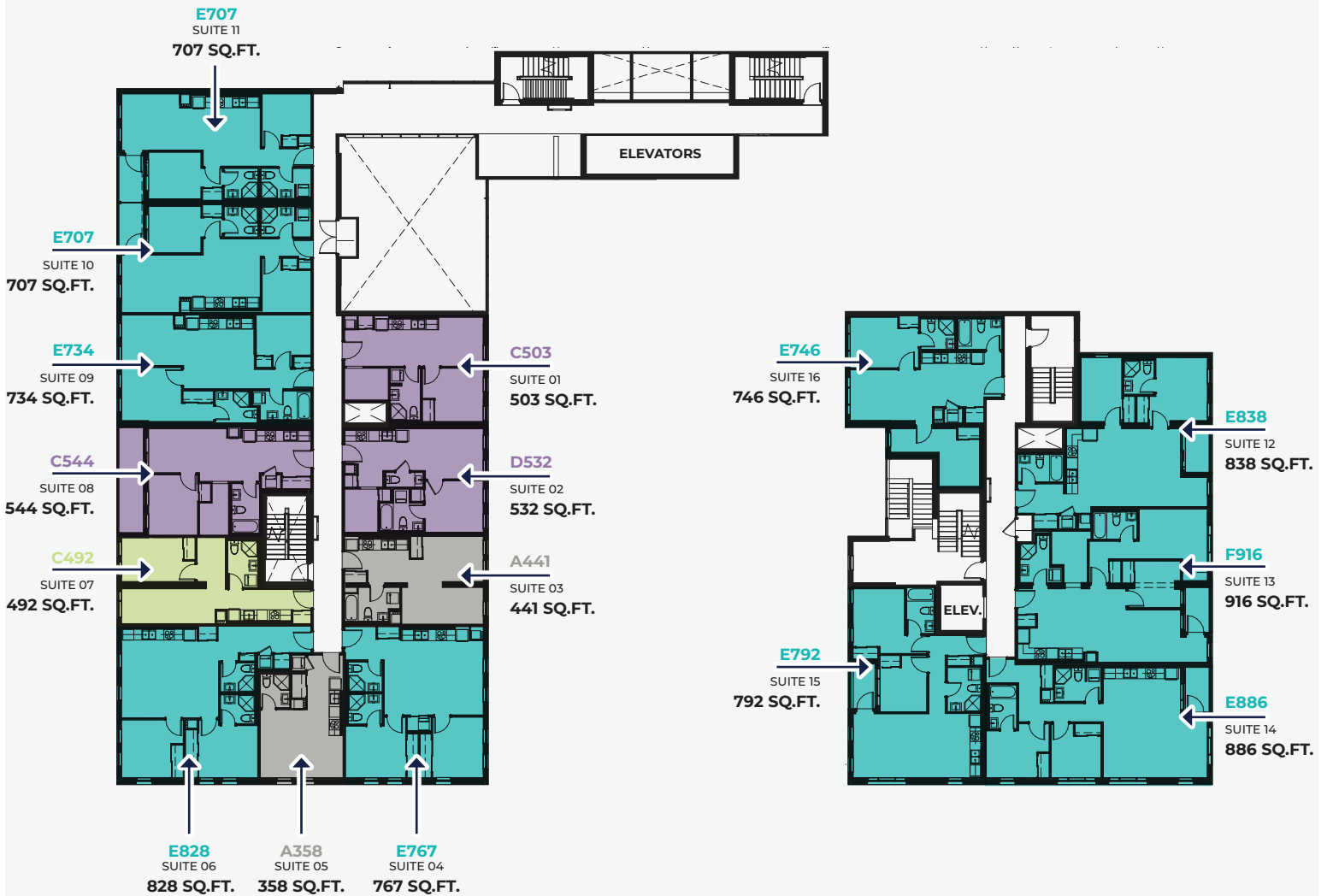

FLOORS 3-4

STUDIO
 1 BED
 1 BED + DEN
 2 BED

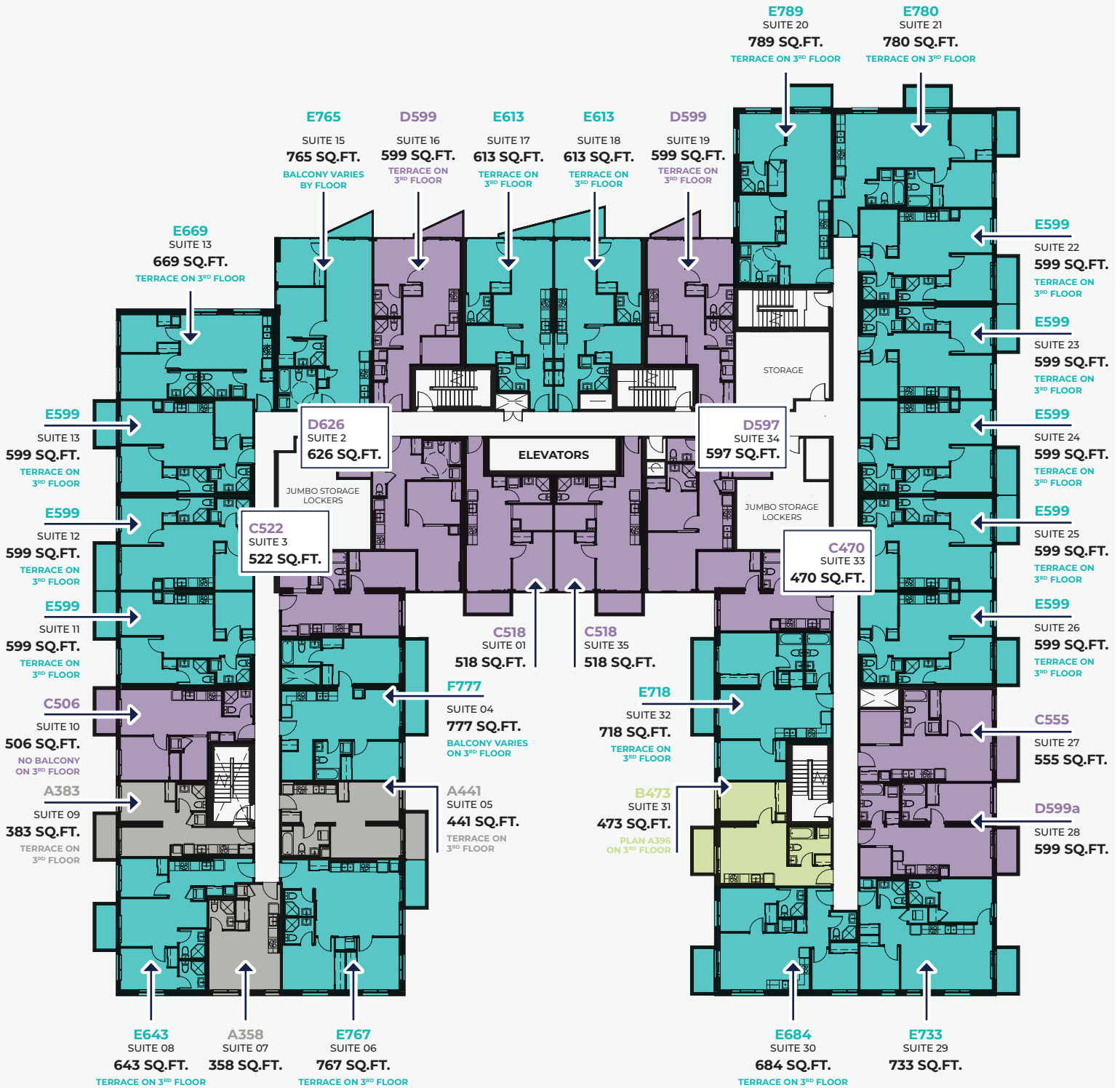

FLOOR 5

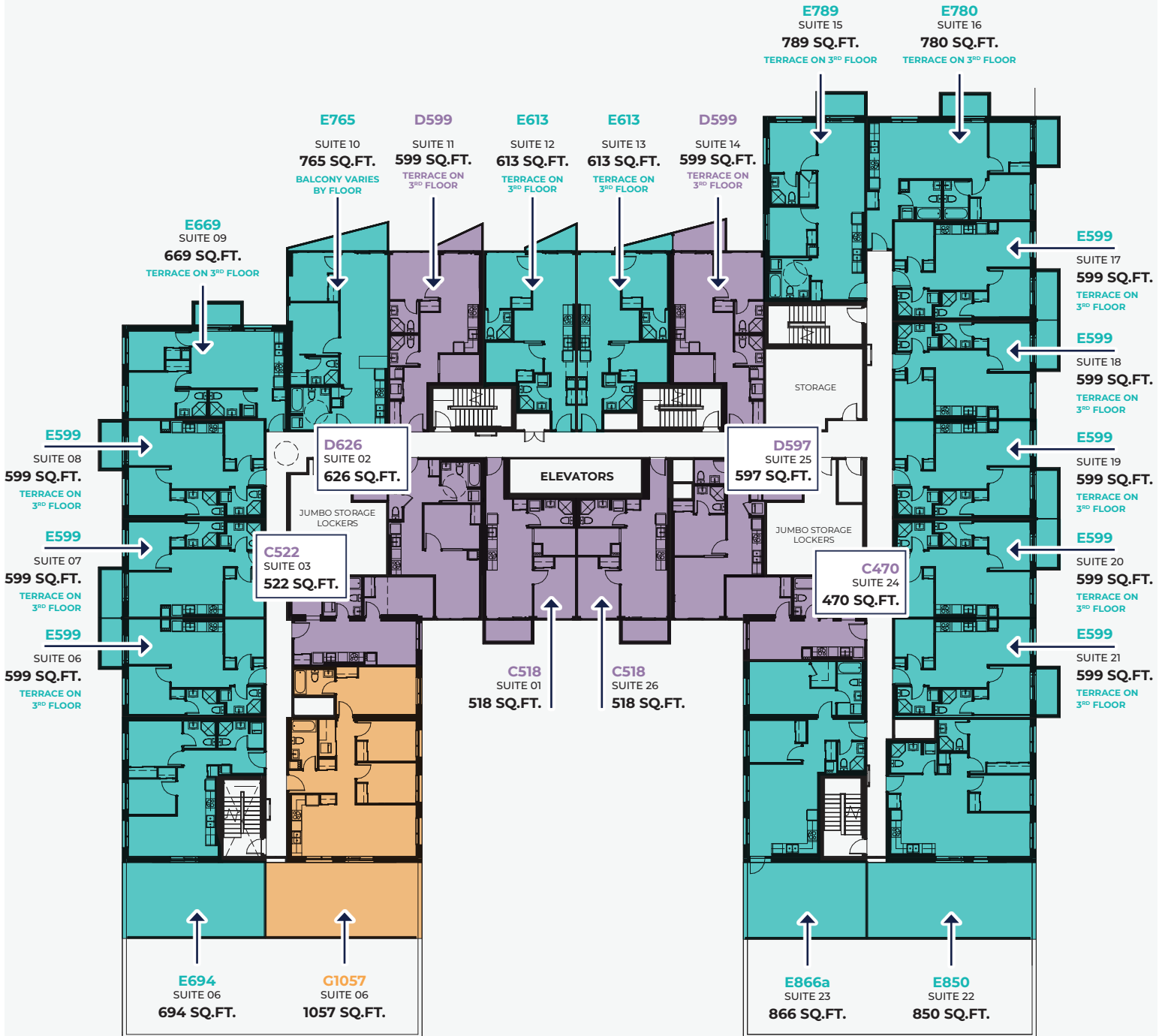

FLOORS 6-7

STUDIO
 1 BED
 1 BED + DEN
 2 BED

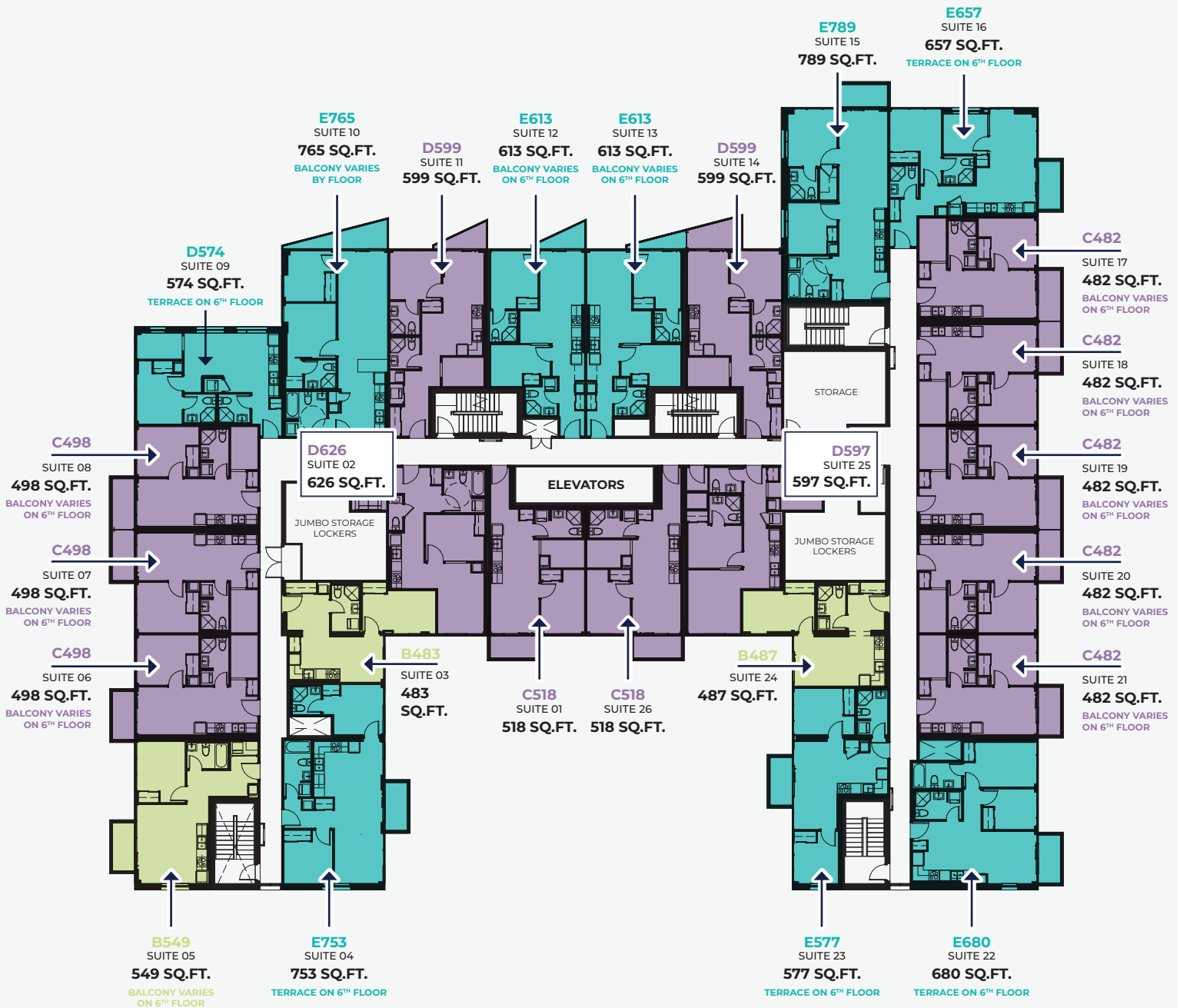

FLOOR 8

- STUDIO
- 1 BED
- 1 BED + DEN
- 2 BED



FLOORS 9-12

STUDIO
 1 BED
 1 BED + DEN
 2 BED
 3 BED

